

ENCE 353 Final Exam, Open Notes and Open Book

Name : _____

Exam Format and Grading. This take home final exam is open notes and open book. You need to comply with the university regulations for academic integrity.

Answer Question 1. Then answer **three of the five** remaining questions. Partial credit will be given for partially correct answers, so please show all your working.

IMPORTANT: Only the **first four questions** that you answer will be graded, so please **cross out the two questions you do not want graded** in the table below.

Question	Points	Score
1	20	
2	10	
3	10	
4	10	
5	10	
6	10	
Total	50	

Question 1: 20 points

COMPULSORY: Moment-Area Method. Figure 1 is a front elevation view of a cantilevered beam carrying a single point load P . EI is constant along the beam structure A-B-C-D.

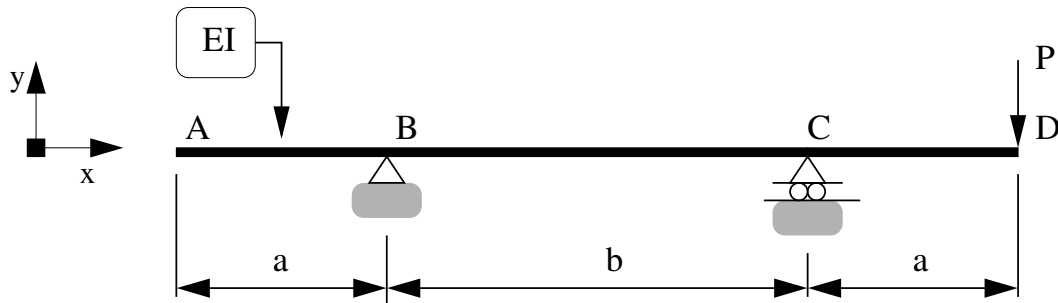

Figure 1: Cantilevered beam carrying a single applied load P .

[1a] (3 pts) Draw and label the M/EI diagram.

[1b] (3 pts) Draw and label the **moment area analysis diagram** (i.e., with rotations, tangents, displacements, etc) for this problem.

[1c] (4 pts) Use the method of **moment area** to show that the anticlockwise rotation of the beam at B is:

$$\theta_B = \frac{Pab}{6EI} \quad (1)$$

and the clockwise rotation of the beam at C is:

$$\theta_C = \frac{Pab}{3EI}. \quad (2)$$

Show all of your working.

[1d] (4 pts) Use the method of **moment area** to show that the vertical deflection of the beam at points A and D (measured downwards) is:

$$y_A = \frac{Pa^2b}{6EI} \quad (3)$$

and

$$y_D = \frac{Pa^2}{3EI} (a + b). \quad (4)$$

Show all of your working.

[1e] (6 pts) Show that the maximum upwards deflection of the beam occurs at a distance $b/\sqrt{3}$ from B, and that its value is:

$$y_{\text{maximum upward}} = \frac{Pab^2}{9\sqrt{3}EI}. \quad (5)$$

Show all of your working.

Question 2: 10 points

OPTIONAL: Superposition and Compatibility of Displacements. Figure 2 is a front elevation view of a cantilevered beam carrying a single point load P at D . A spring is attached to the beam at A . EI is constant along the beam structure A - B - C - D .

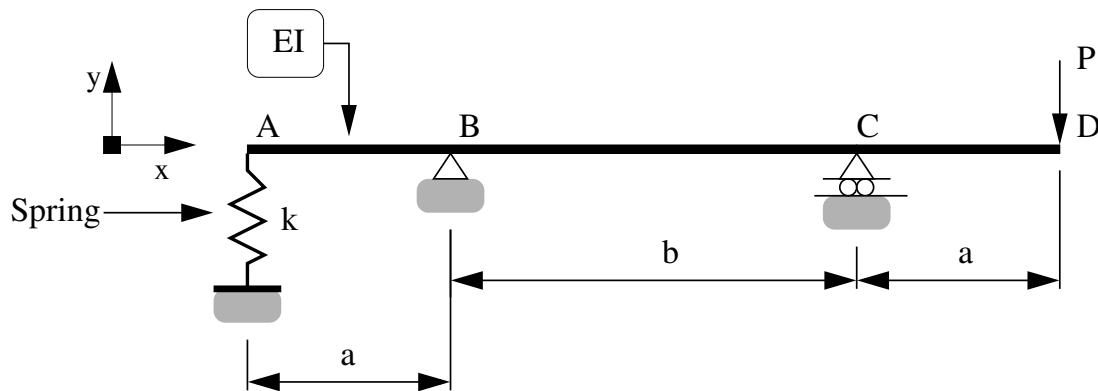

Figure 2: Cantilevered beam and spring.

This question builds upon the results of Question 1 – please feel free to use equations 1 through 5 in your solution to this problem.

[2a] (4 pts) Show that the force in the spring, S , is given by:

$$\left[\frac{a^2(a+b)}{3EI} + \frac{1}{k} \right] S = \frac{Pa^2b}{6EI}. \quad (6)$$

[2b] (2 pts) Briefly explain how the deflection at D will be affected by the spring at A .

[2c] (4 pts) Now suppose that the spring is replaced by a roller support, as shown in Figure 3.

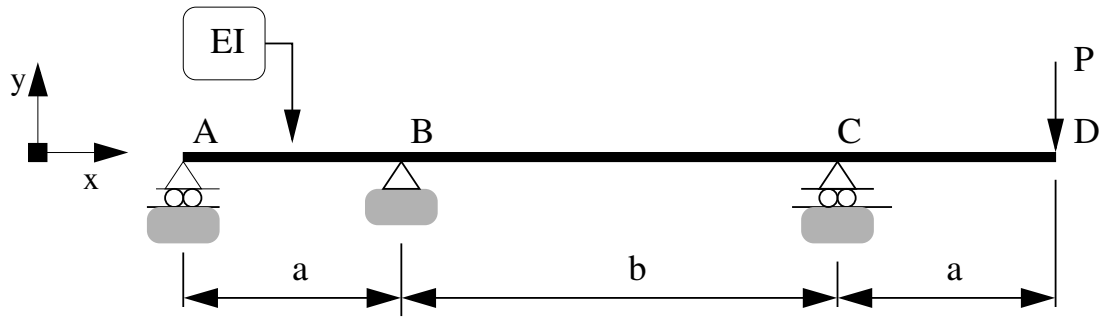

Figure 3: Multi-span beam structure.

Show that the reaction force at A is:

$$V_A = \frac{P}{2} \left[\frac{b}{a+b} \right]. \quad (7)$$

Question 3: 10 points

OPTIONAL: Computing Displacements with the Method of Virtual Forces. Figure 4 is a front elevation view of a dog-leg cantilever beam carrying a point load P (N) at point D.

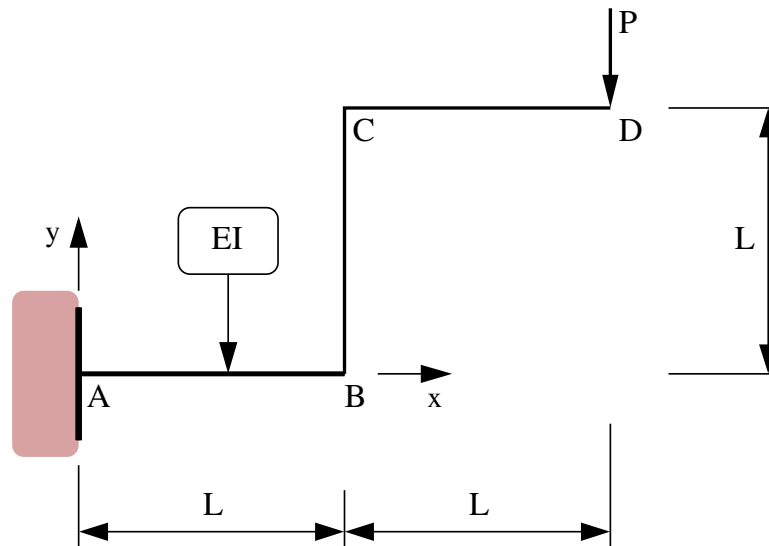

Figure 4: Dog-leg cantilever beam carrying end moment M (N.m).

The flexural stiffness EI is constant along A-B-C-D. The axial stiffness EA is very high and, as such, axial displacements can be ignored in the analysis.

[3a] (4 pts) Use the method of **virtual forces** to show that the clockwise rotation of the beam at point D is:

$$\theta_d = \frac{3PL^2}{EI}. \quad (8)$$

[3b] (6 pts) Use the method of **virtual forces** to show that the horizontal (measured left-to-right) and vertical (measured downwards) displacements at D are:

$$\Delta_h = \frac{2PL^3}{EI}. \quad (9)$$

and

$$\Delta_v = \frac{11 PL^3}{3 EI}. \quad (10)$$

respectively. Show all of your working.

Question 3b continued ...

Question 4: 10 points

OPTIONAL: Structural Analysis with Method of Virtual Displacements. The cantilevered beam structure shown in Figure 5 supports a triangular load distributed over the beam section B-C-D. At point B the loading is zero; at point D the maximum loading is W_o (N/m).

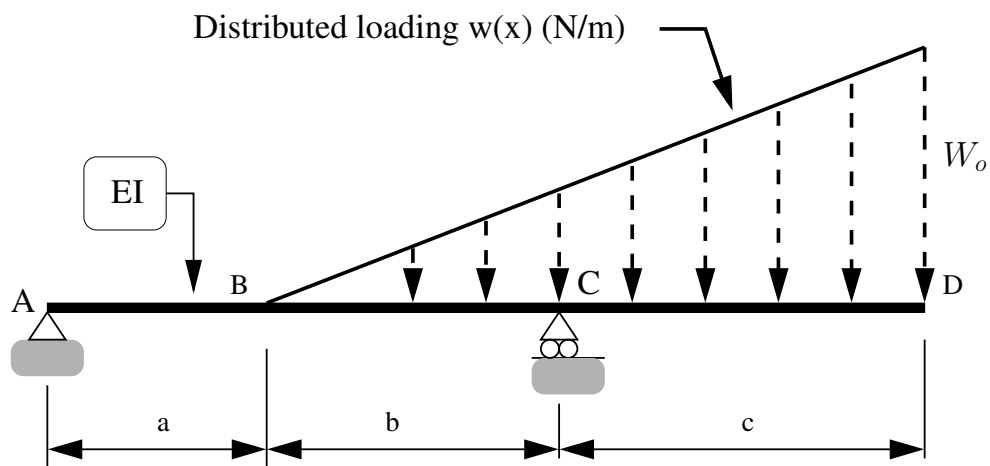

Figure 5: Front elevation view of a simple beam structure.

[4a] (4 pts) Use the method of **virtual displacements** to compute formulae for the vertical reactions at A and C. Show all of your working.

[4b] (6 pts) Use the method of **virtual displacements** to compute a formula for the bending moment at B. Show all of your working.

Question 5: 10 points

OPTIONAL: Zero-Force Members and Principle of Virtual Work. Consider the truss structure shown in Figure 6.

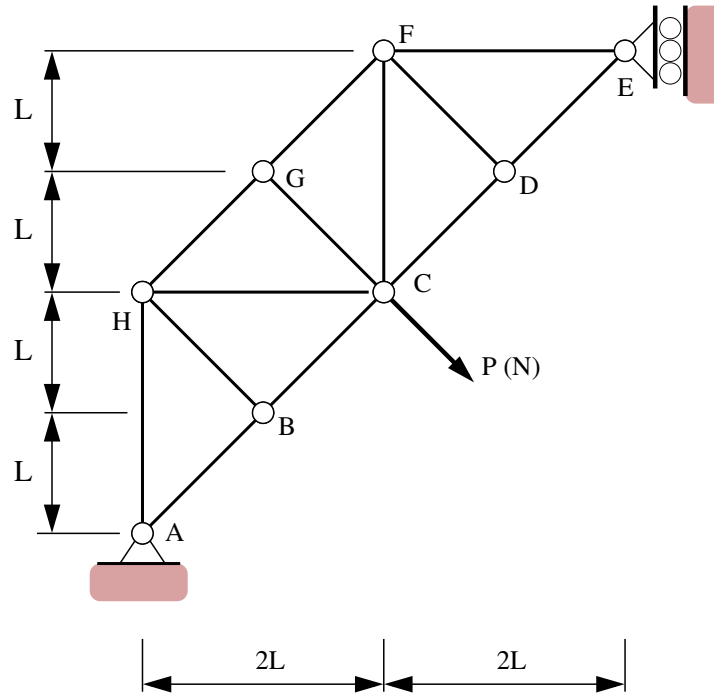

Figure 6: Elevation view of simple truss structure.

All of the members have cross section properties AE . A single point load $P(N)$ is applied at node C as shown in the figure.

[5a] (2 pts). Identify the zero-force members and the axis of symmetry in this problem (If you wish, you can simply annotate Figure 6).

[5b] (3 pts). Compute the support reactions and distribution of forces throughout the structure.

[5c] (5 pts). Use the method of **virtual forces** to compute the total displacement of node C.

Question 6: 10 points

OPTIONAL: Virtual Work and Flexibility Matrices. Consider the truss structure shown in Figure 7.

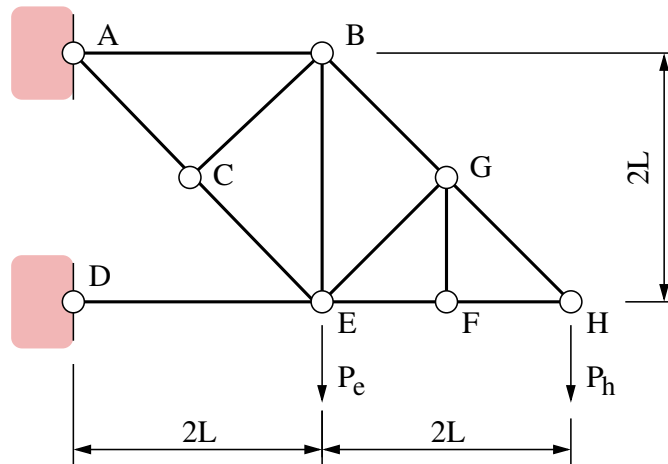

Figure 7: Elevation view of a pin-jointed truss.

The horizontal and vertical degrees of freedom are fully-fixed at supports A and D. The truss carries vertical loads P_e and P_h at nodes E and H, respectively. Frame members **AC**, **CE** and **DE** have members have cross section properties $2AE$. Otherwise, the members have cross section properties AE .

[6a] (3 pts) Use the method of **virtual forces** to compute the vertical deflection at node E due to load P_e alone (i.e., $P_h = 0$).

[6b] (3 pts) Use the method of **virtual forces** to compute the vertical deflection at node H due to load P_h alone (i.e., $P_e = 0$).

[6c] (4 pts) Use the method of **virtual forces** to compute the two-by-two flexibility matrix connecting the vertical displacements at points E and H to applied loads P_e and P_h , i.e., as a function of P_e , P_h , L and AE.

$$\begin{bmatrix} \Delta_e \\ \Delta_h \end{bmatrix} = \begin{bmatrix} f_{11} & f_{12} \\ f_{21} & f_{22} \end{bmatrix} \begin{bmatrix} P_e \\ P_h \end{bmatrix}. \quad (11)$$

Question 6c continued ...