

# ENCE 353: An Overview of Structural Analysis and Design

Mark Austin

Fall Semester 2011

# Outline

- Objective of Structural Engineering
- Structural Engineering Process
- Types of loads
- Types of structures
- Civil Engineering Materials
- Load paths in structures
- How can structures fail?
- Summary

# Objectives of Structural Engineering

Structural engineering is the ...

....science and art of designing and making, with economy and elegance, buildings, bridges, frameworks, and other structures so that they can safely resist the forces to which they may be subjected.

Design: process of determining location, material, and size of structural elements to resist forces acting in a structure

# Structural Design Process

- Determine types magnitudes of loads and forces acting on the structure
- Determine structural context
  - geometric and geological information
  - cost / schedule / height/ etc. limitations
- Generate alternative structural systems (e.g., moment resistant frame, materials selection),
- Analyze one or more alternatives
- Select and perform detailed design
- Implement (usually done by contractor)

**Note:** New structural systems may also require an experimental testing phase to verify behavior and system performance.

# Formal Approach to Structural Design

## Formal Approaches to Behavior Modeling and Decision Making

Appropriate formalisms depend on the design domain of interest.

- Physical aspects of behavior are often characterized by differential equations.
- Logical aspects of system design can be captured by binary and multi-valued logic variables and boolean equations.

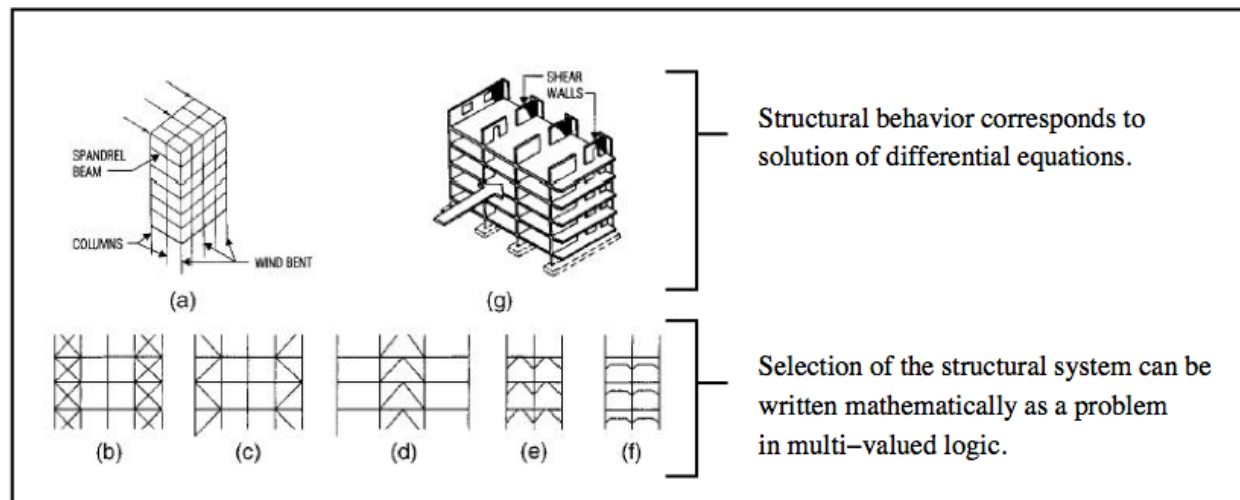

# Formal Approach to Structural Design

## Structural Behavior

Time-dependent behavior corresponds to solutions of:

$$[M] \frac{d^2 x}{dt^2} + [C] \frac{dx}{dt} + [K] x = P(t). \quad (1)$$

Here,

- M, C, and K are  $(n \times n)$  matrices,
- x is a  $(n \times 1)$  vector of displacements,
- P(t) is a vector of external loads applied to the structural degrees of freedom.

## Design Parameters

- Selection of the best structural system (e.g., braced system) from a list of options.
- Size of the beams, columns, and bracing (if required).

# Types of loads

- Dead loads
- Live loads
- Dynamic loads (e.g., trains, equipment)
- Wind loads
- Earthquake loads
- Thermal loads
- Settlement loads

# Dead Loads

- weight of the structure itself
  - floors, beams, roofs, decks, beams/stringers, superstructure
- loads that are “always there”





# Live Loads

- People, furniture, equipment
- Loads that may move or change mass or weight
- Minimum design loadings are usually specified in the building code



# Load Example: Live Load in Ballroom

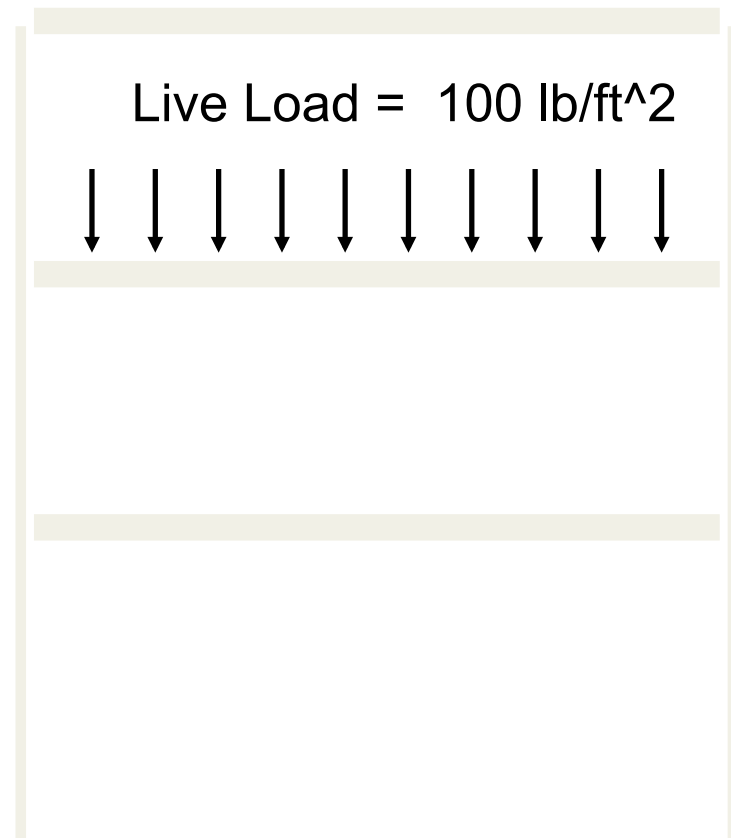
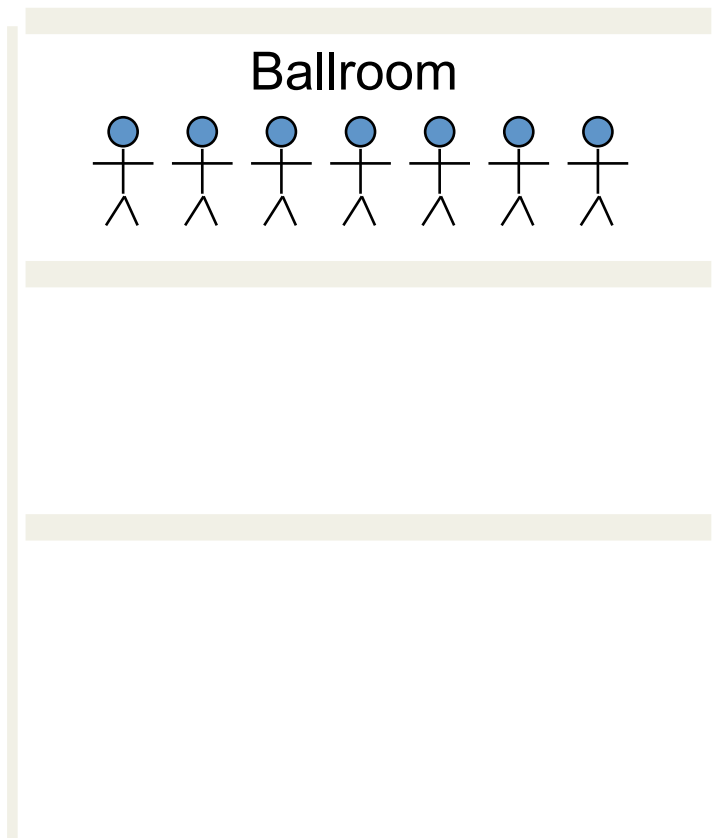

# Dynamic Loads

- Moving loads (e.g., traffic)
- Impact loads
- Gusts of wind
- Loads due to cycling machinery



# Load Example: Dynamic Load

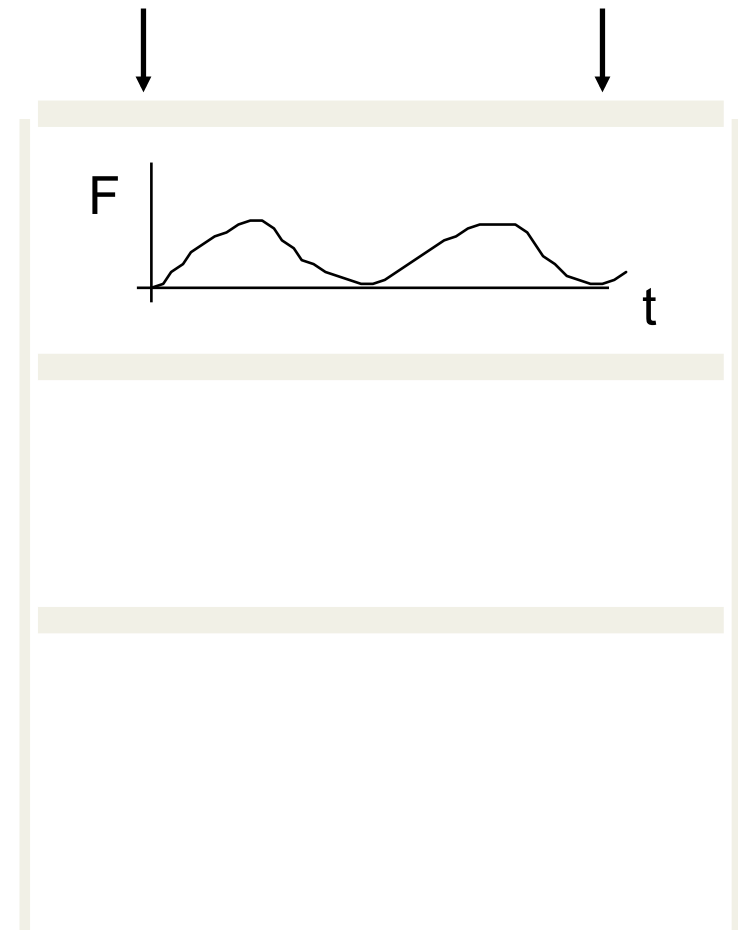
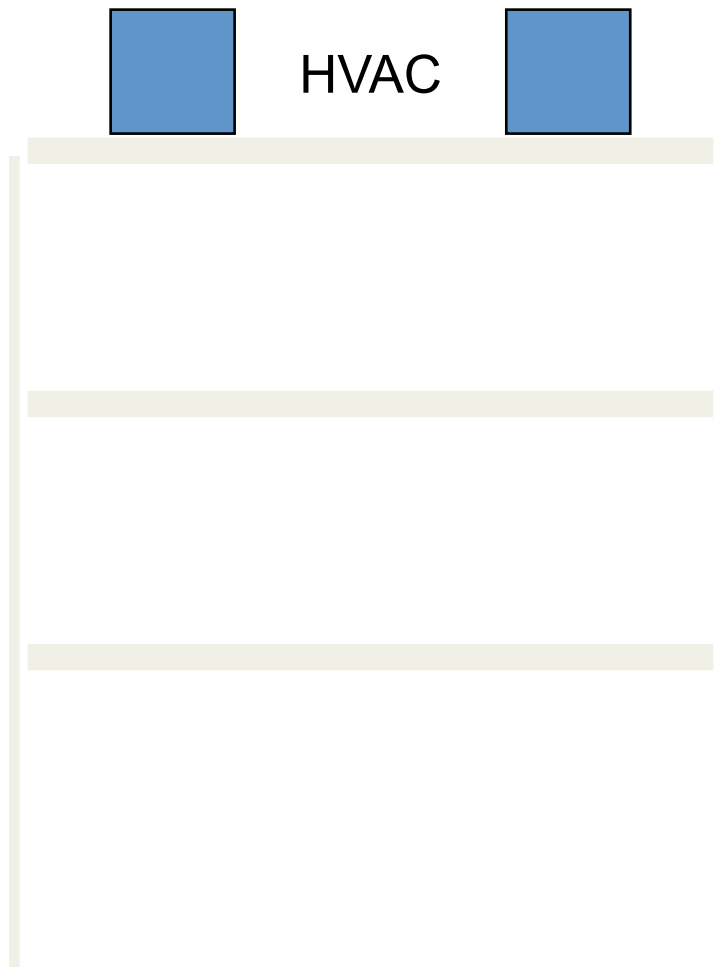

# Load Example: Water in a dam

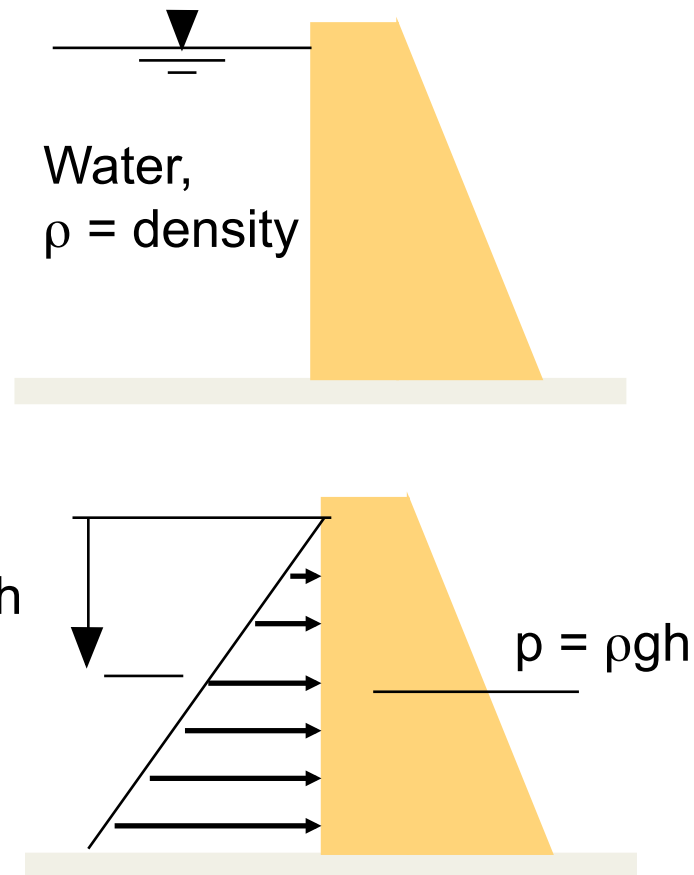

# Earthquake Loads

- Structure loaded when base is shaken
- Response of structure is dependent on the frequency of motion
- When frequencies match with natural frequency of structure - resonance

# Load Example: Earthquake Load

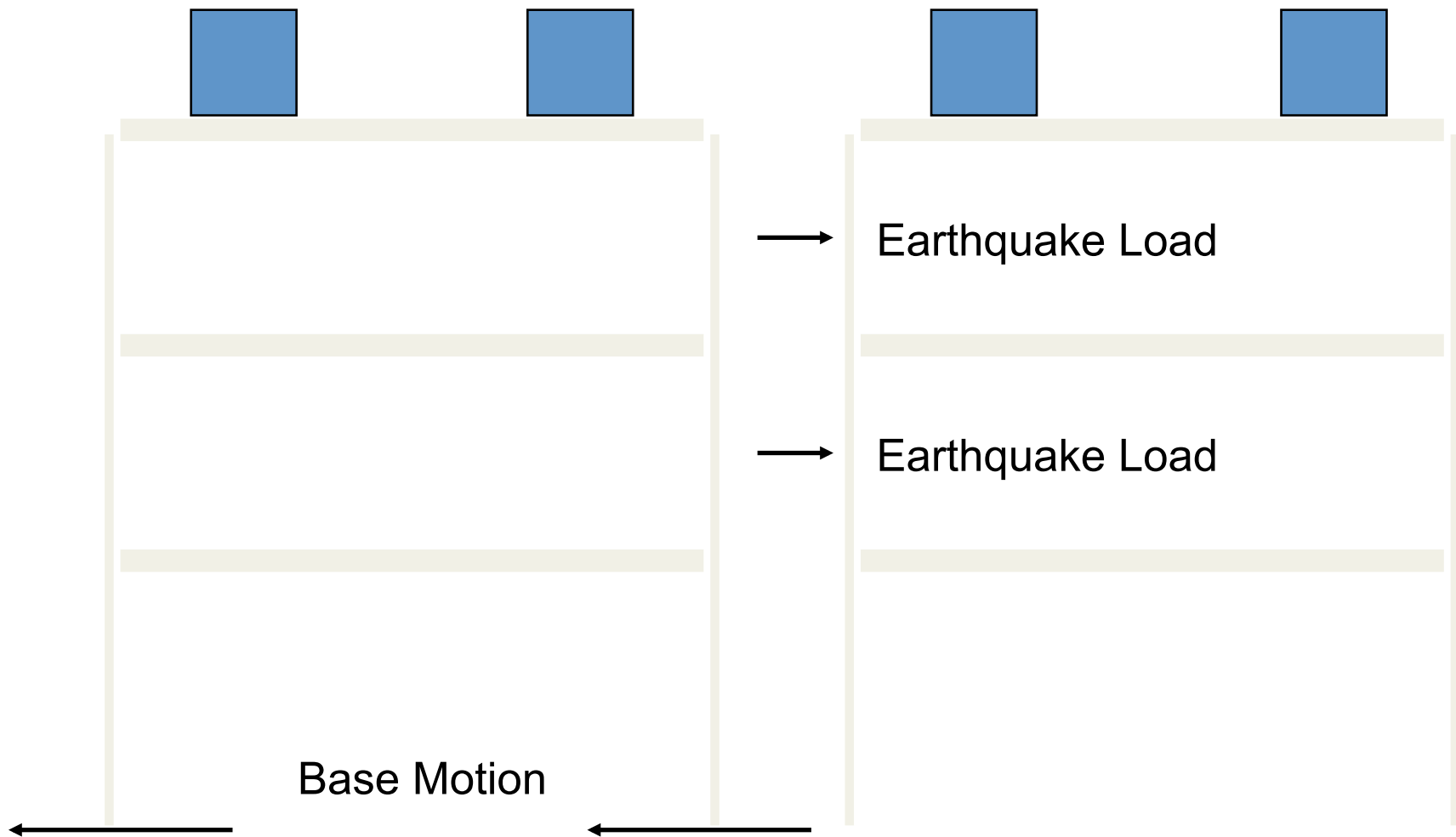

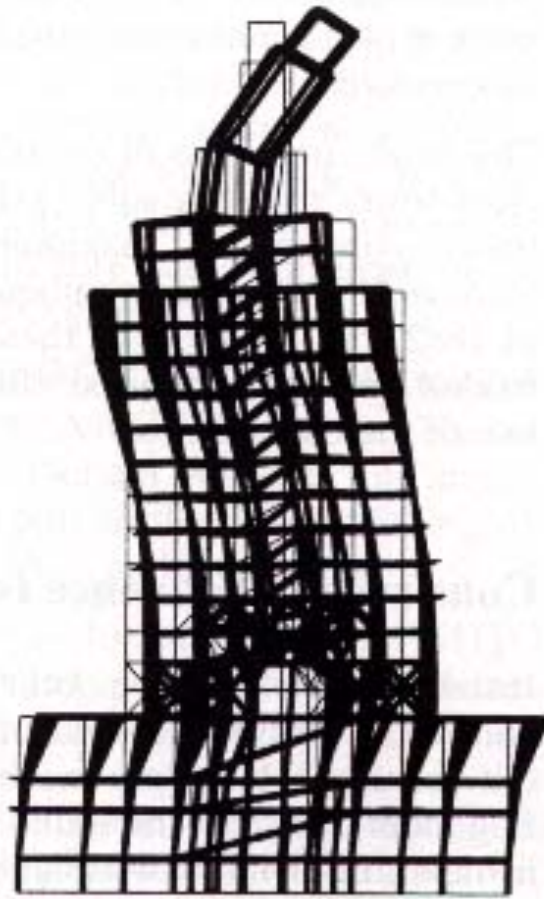

Fixed Base

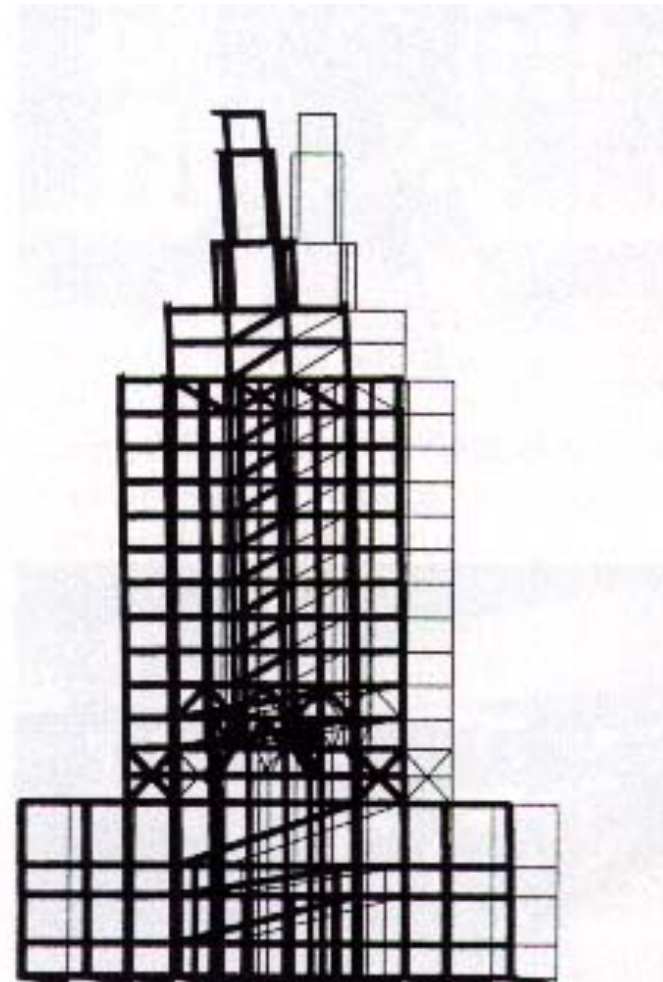

Isolated

*4: Seismic response of the building*



# Settlement



...the structure, I accepted the appointment in spite of my advanced age, then 80. I was determined to see that the Tower survived.

The Committee was constituted as follows:

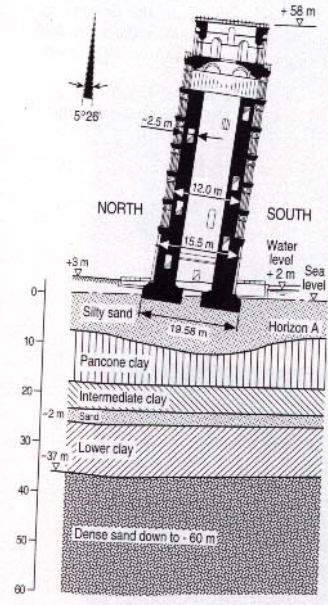

Fig. 2: Soil profile

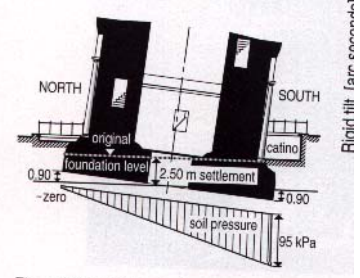
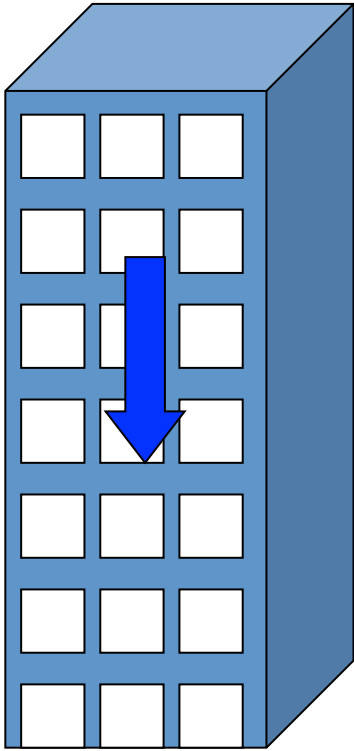

Fig. 3: Settlement and soil pressure

# Forces Acting in Structures

- Forces induced by gravity
  - Dead Loads (permanent): self-weight of structure and attachments
  - Live Loads (transient): moving loads (e.g. occupants, vehicles)
- Forces induced by wind
- Forces induced by earthquakes
- Forces induced by rain/snow
- Fluid pressure

# Forces Acting in Structures



Vertical: Gravity

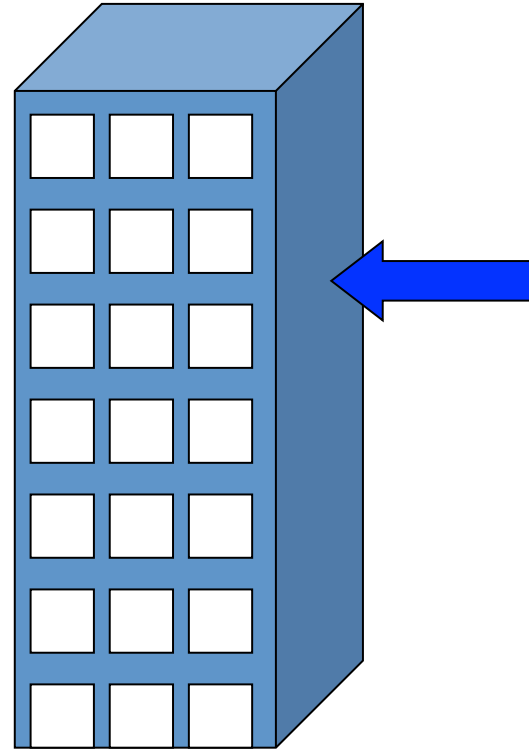

Lateral: Wind, Earthquake

# Global Stability

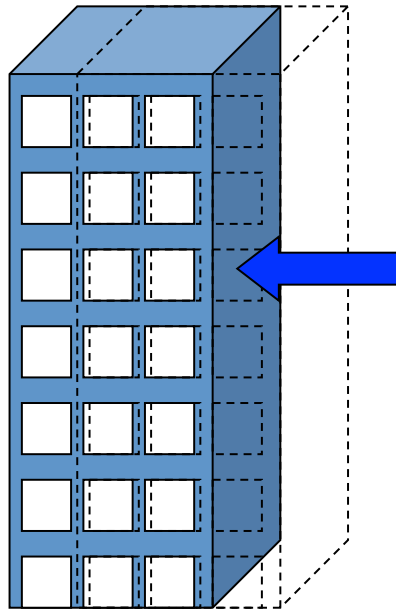

Sliding

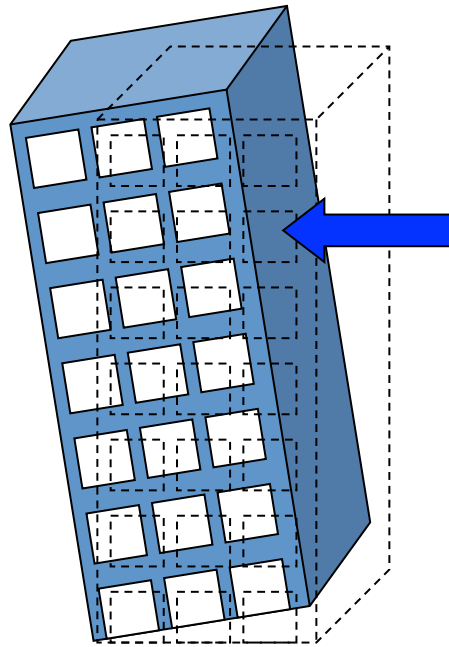

Overturning



# Forces in Structural Elements

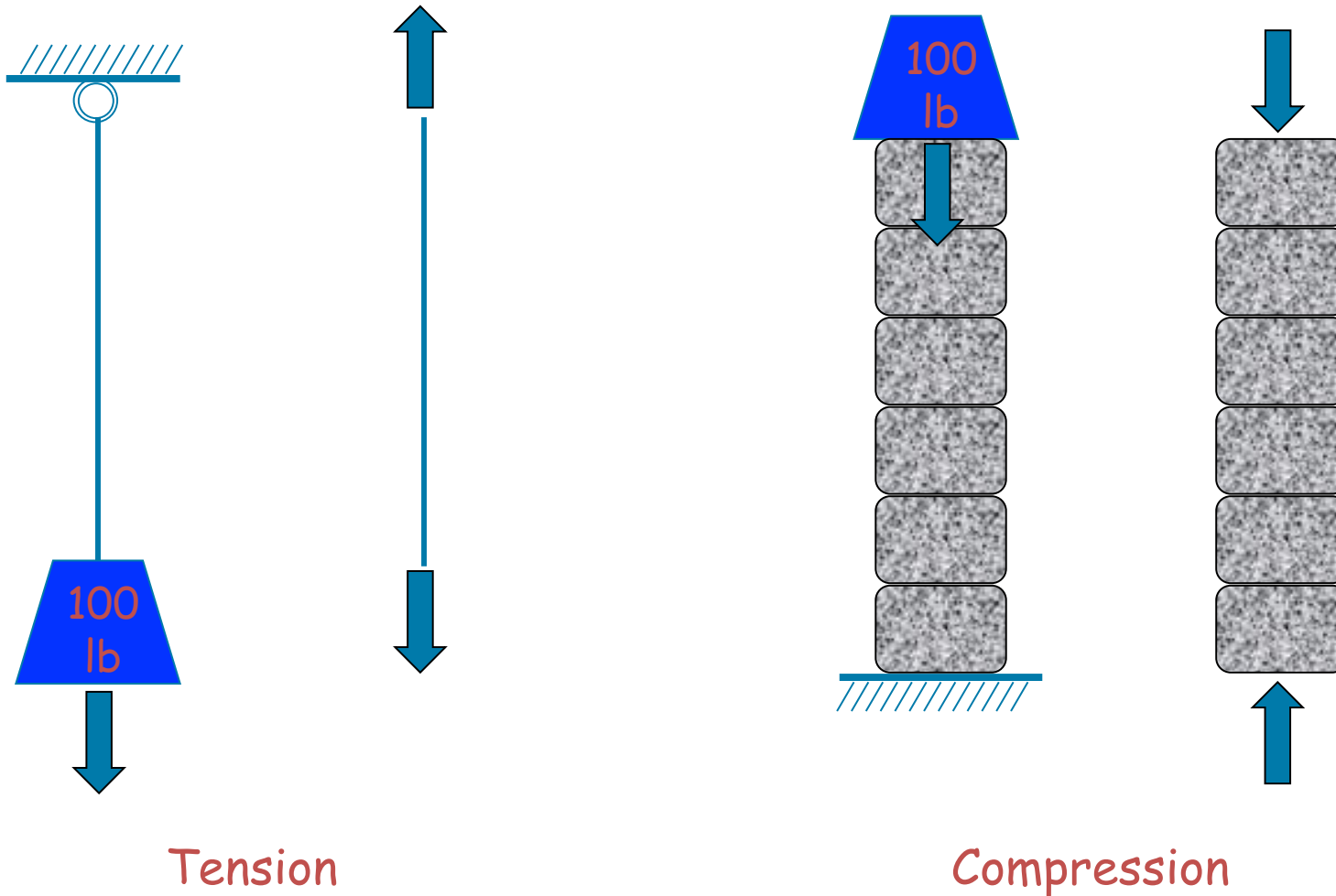

# Forces in Structural Elements (cont.)

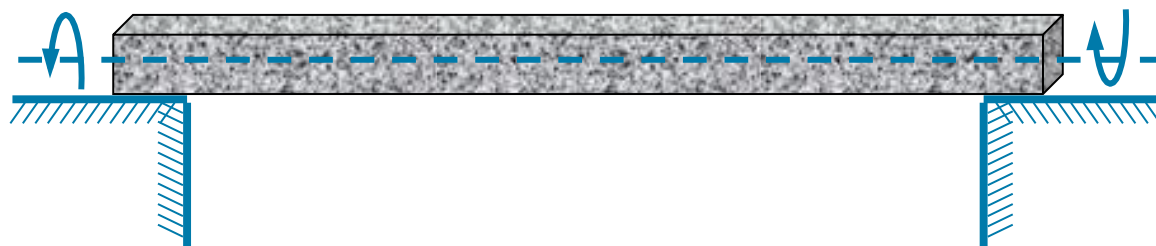
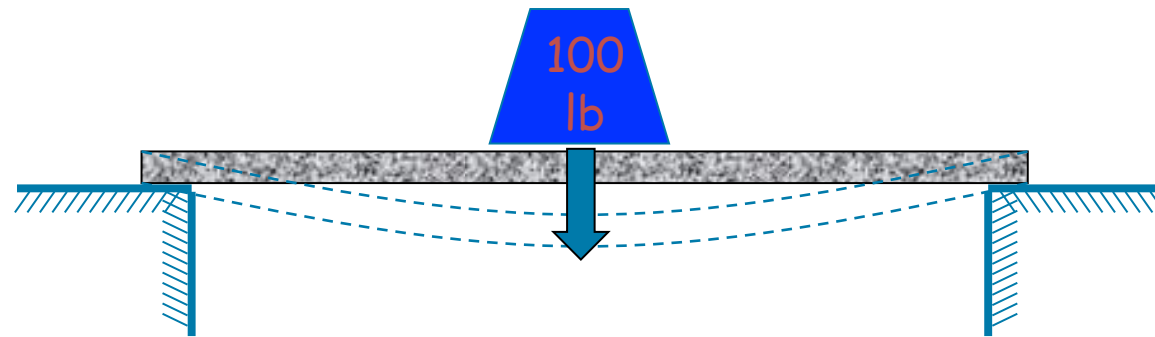

# Some Types of Structures

- Arch
- Planar Truss
- Beam/Girder
- Flat plate
- Braced and Rigid Frames
- Folded Plate and Shell Structures
- Cable Suspended Structure

# Arch

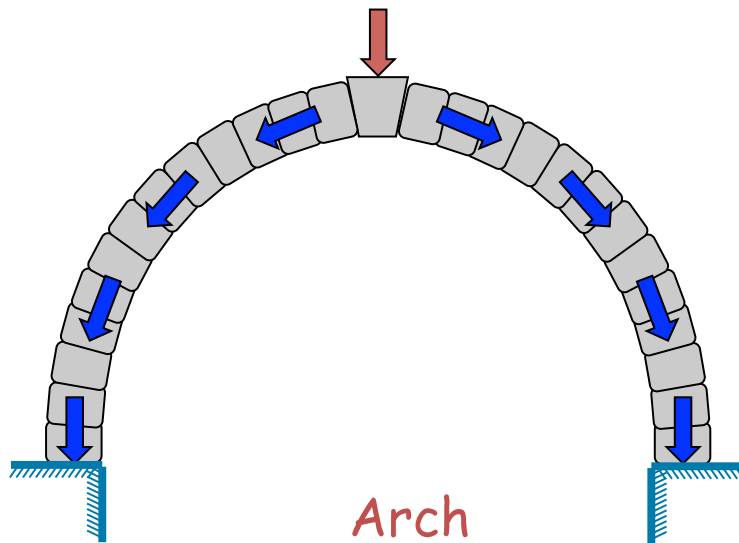

**Design objective:** Structure needs to work and be aesthetically pleasing!!

**Analysis objective:** What shape should the arch be so that forces can be transferred to the foundation through compression mechanisms alone?

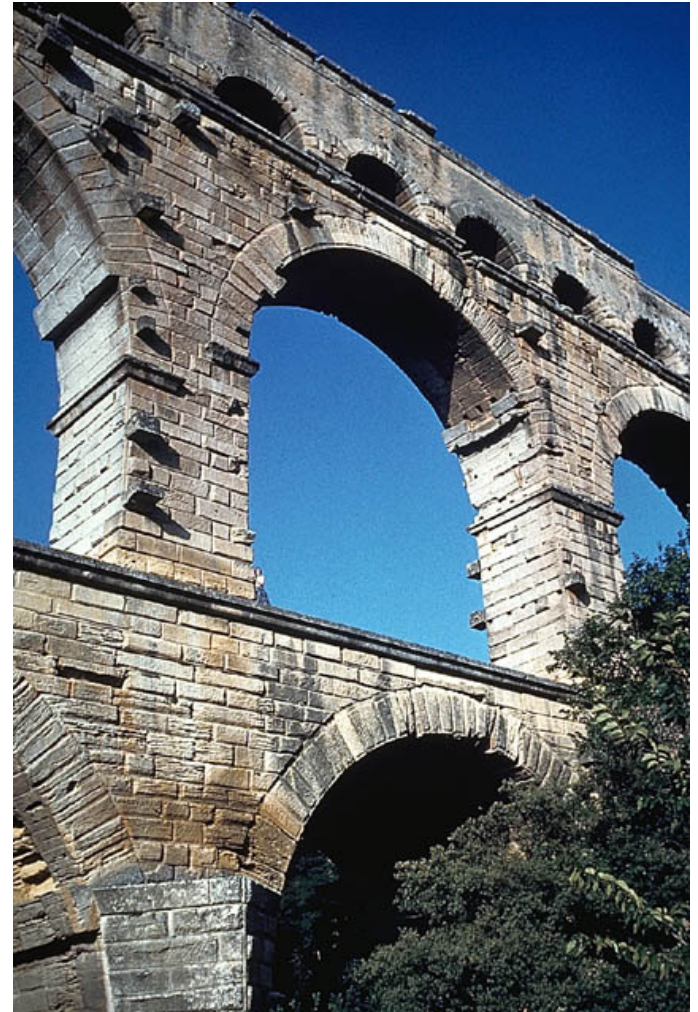





# Planar Truss

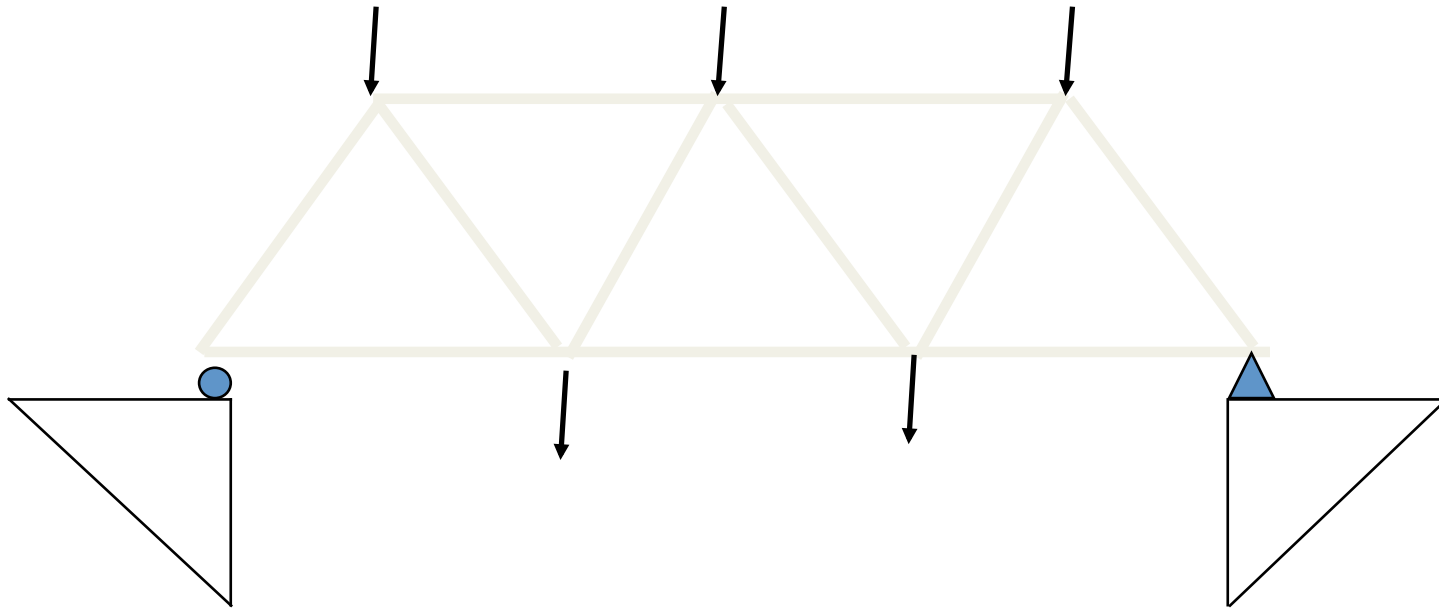

# Planar Truss

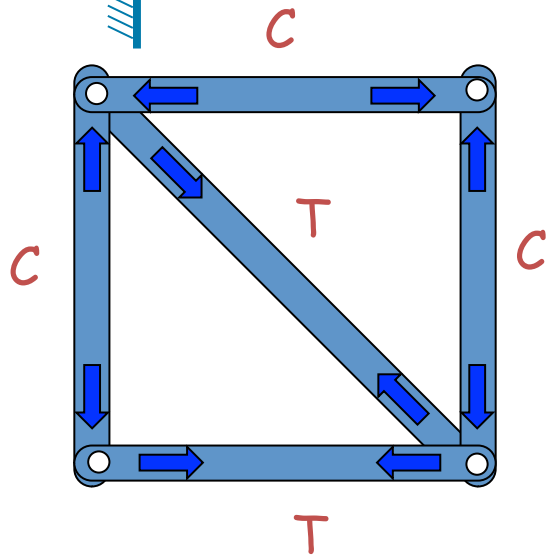
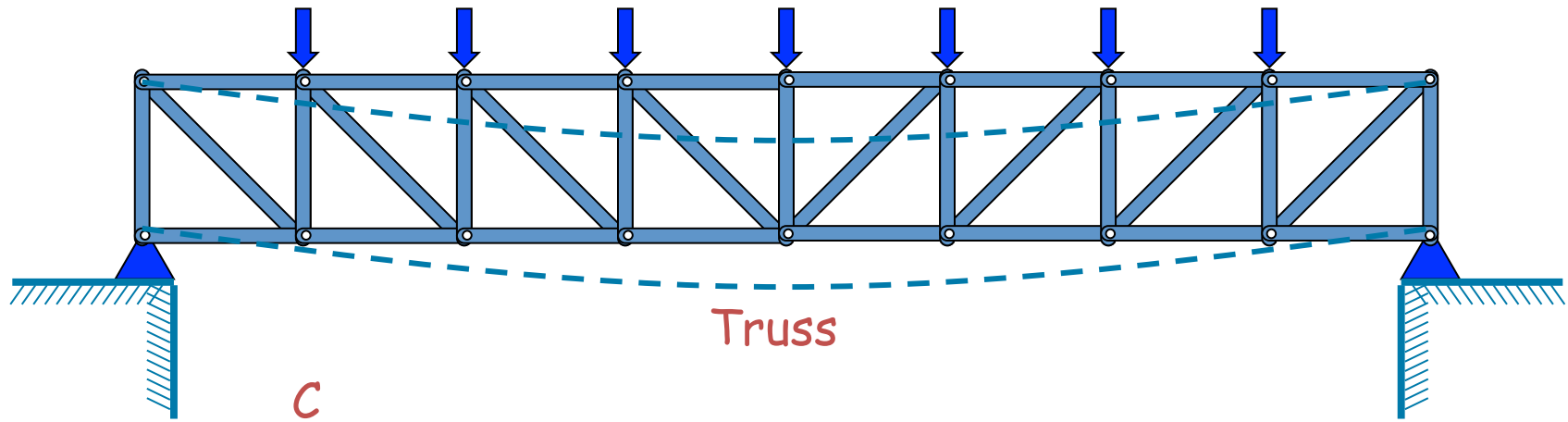

Forces in Truss Members





# Truss

- Combination of square and triangle
  - Both vertical and lateral support

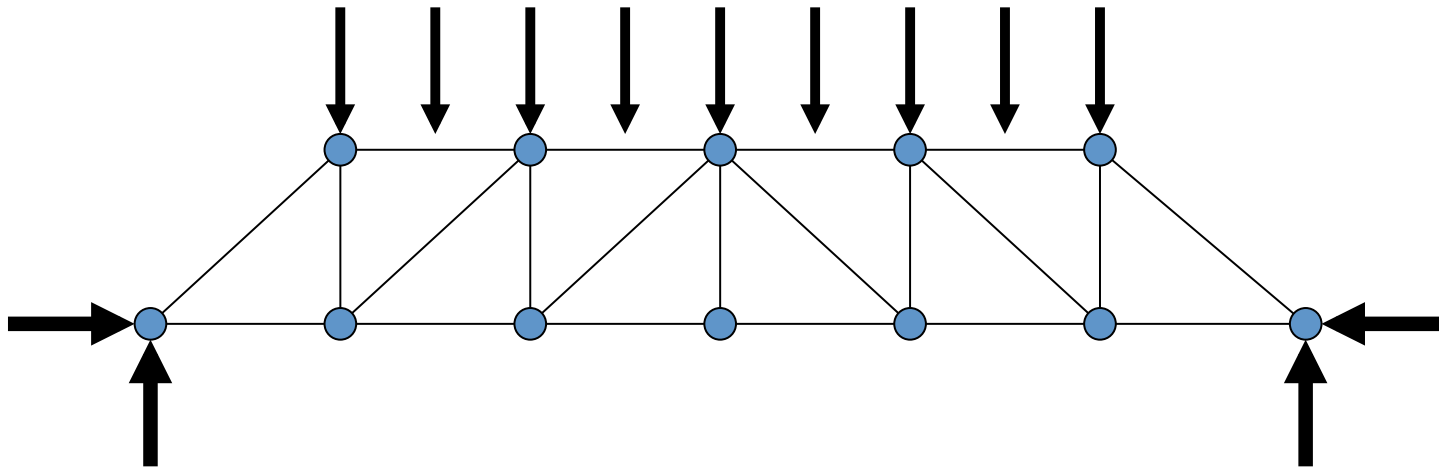

# Beam/Girder

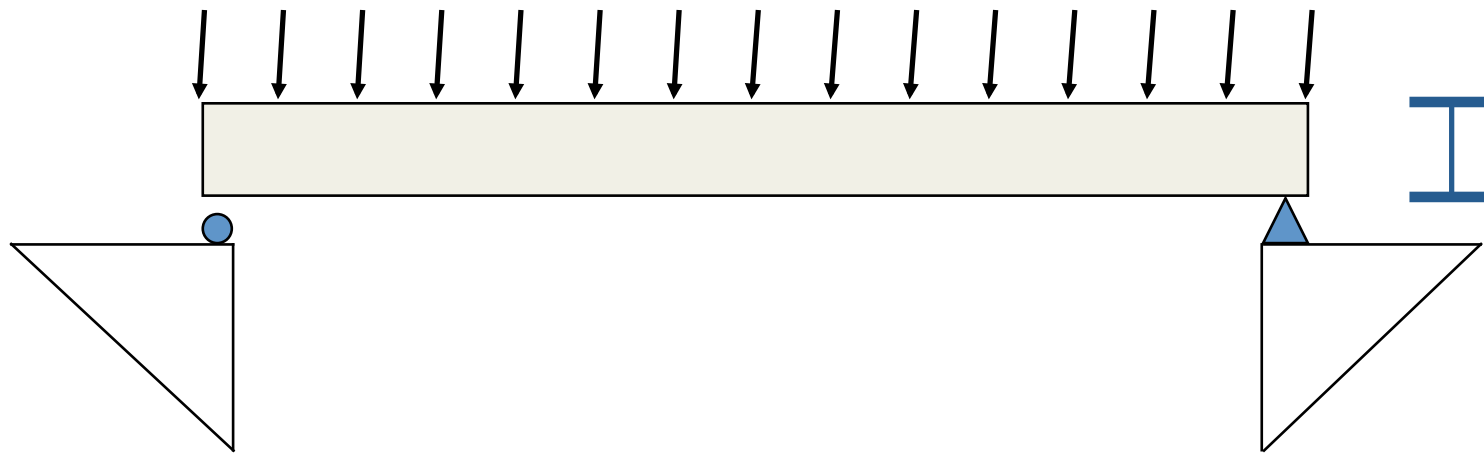



# Frames

Braced

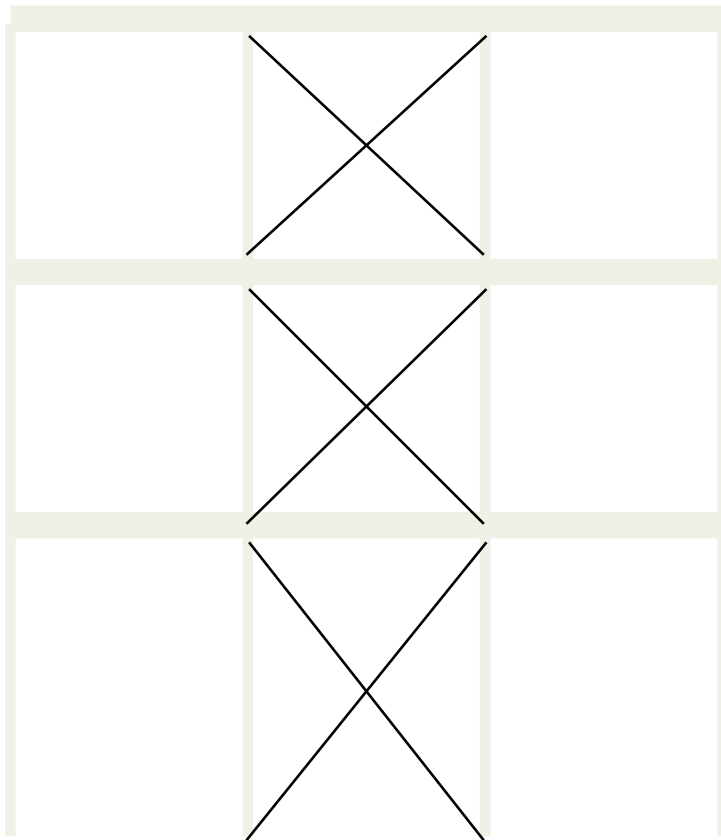

Rigid

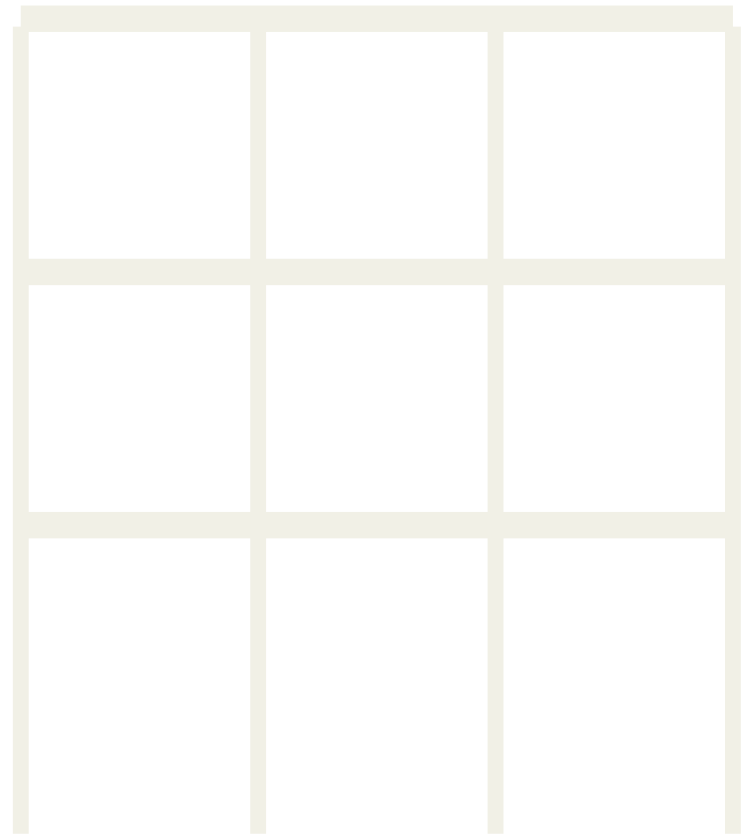



# Frames Continued

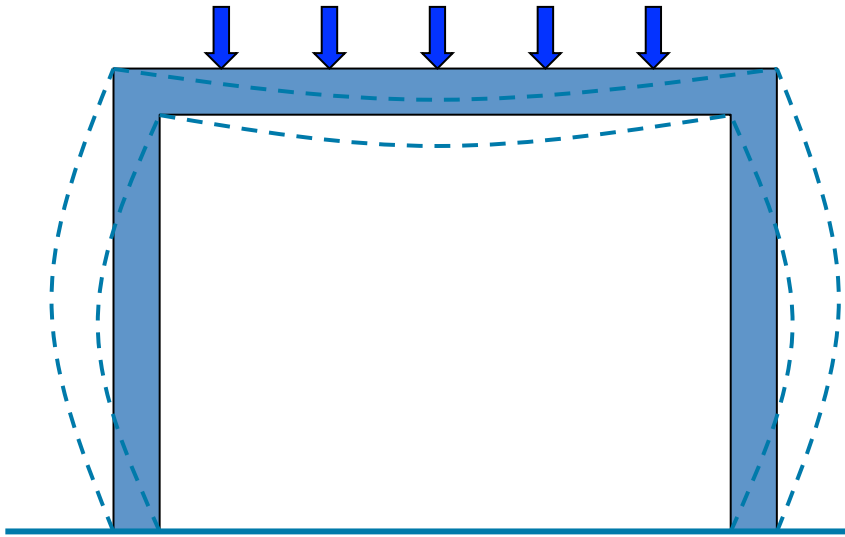

Frame



**Analysis objective:** We want to compute the distribution of forces – axial, bending moment, shear forces – throughout the structure.  
What are the displacements?  
Will the frame structure be stable?



# Flat Plate



# Folded Plate



# Shells



Circular Shell Structure



Lattice Shell Structure

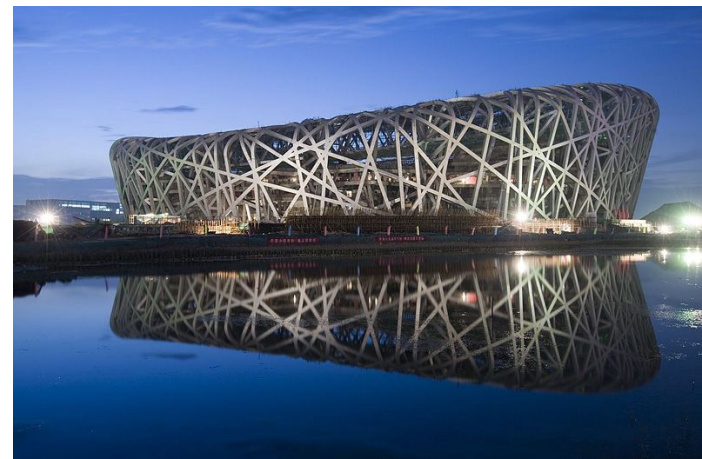

# Cable Suspended Structure

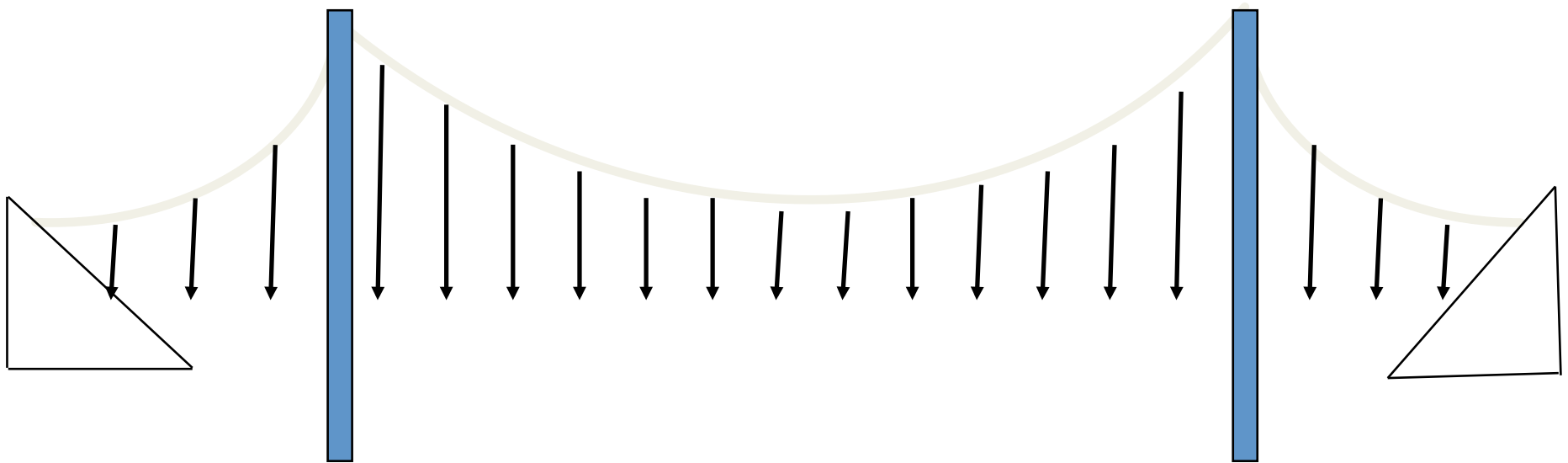

**Analysis objective:** What are the forces in the cable structure? How will the cable profile shape change with different distributions of live load? What are the bending moments in the bridge deck?



# Cable Stayed Bridge

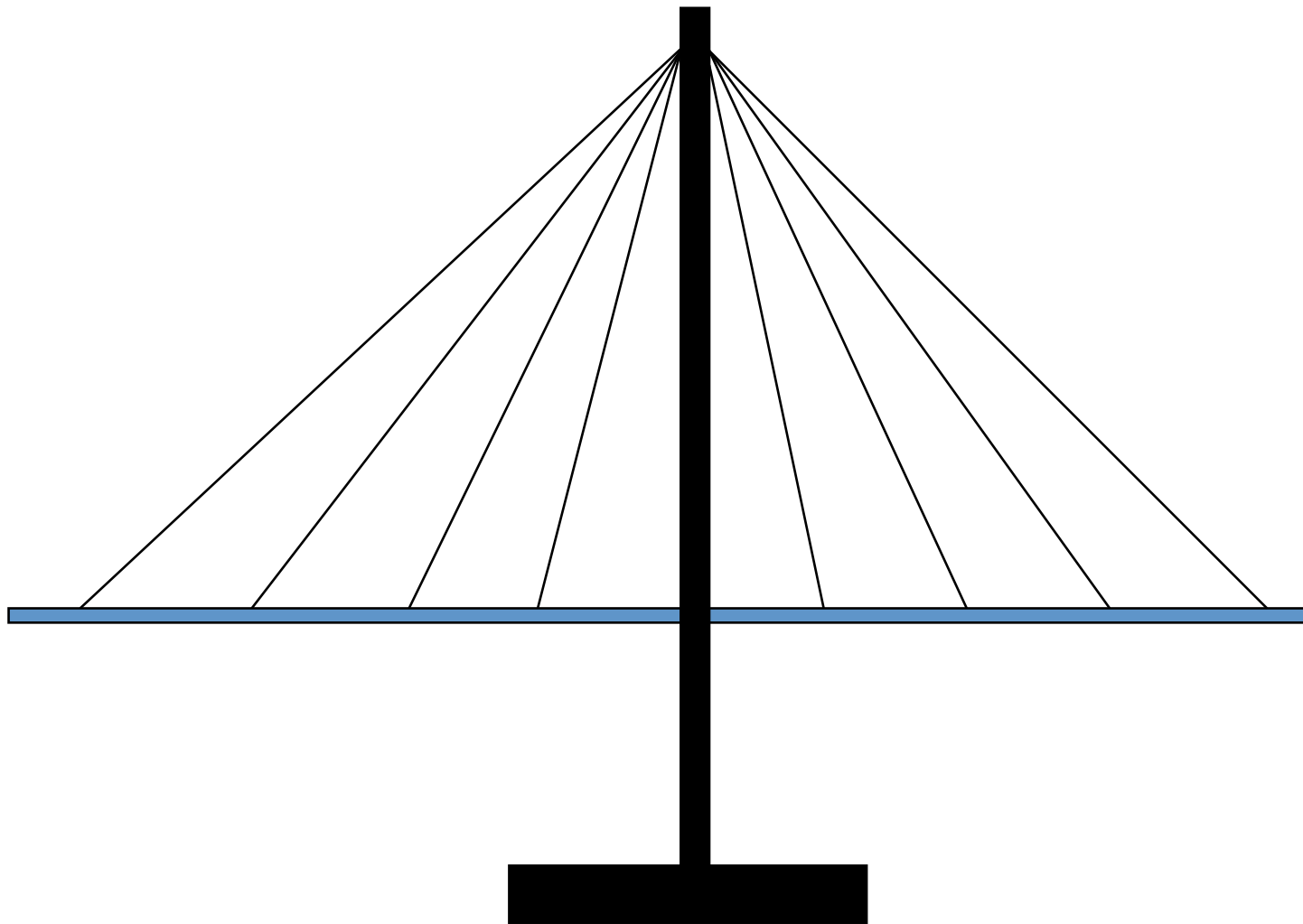



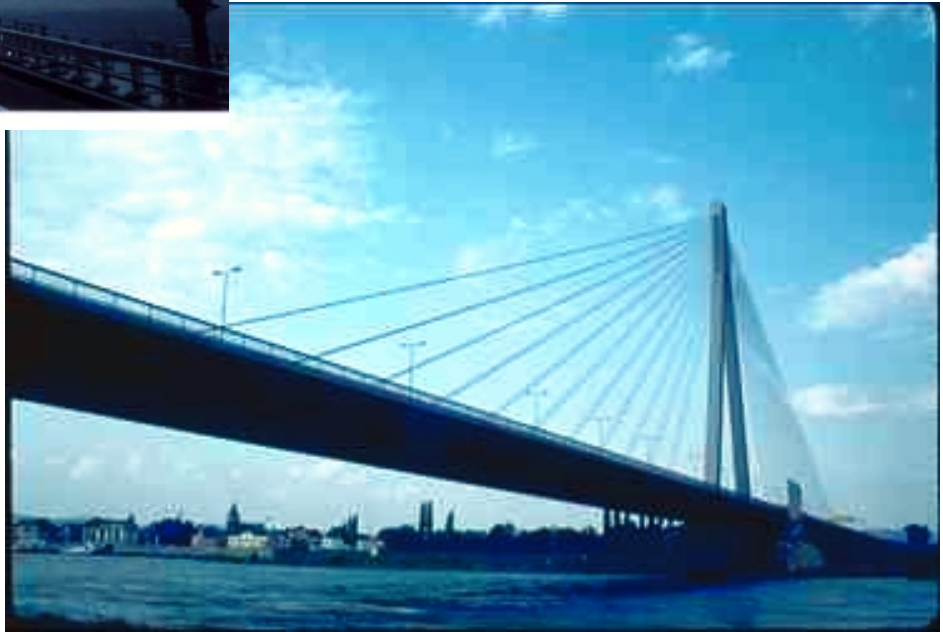

# Load Paths in Structures

- Load Path is the term used to describe the path by which loads are transmitted to the foundations
- Different structures have different load paths
- Some structures have only one path
- Some have several (redundancy good)

# Load Path in Framed Structure

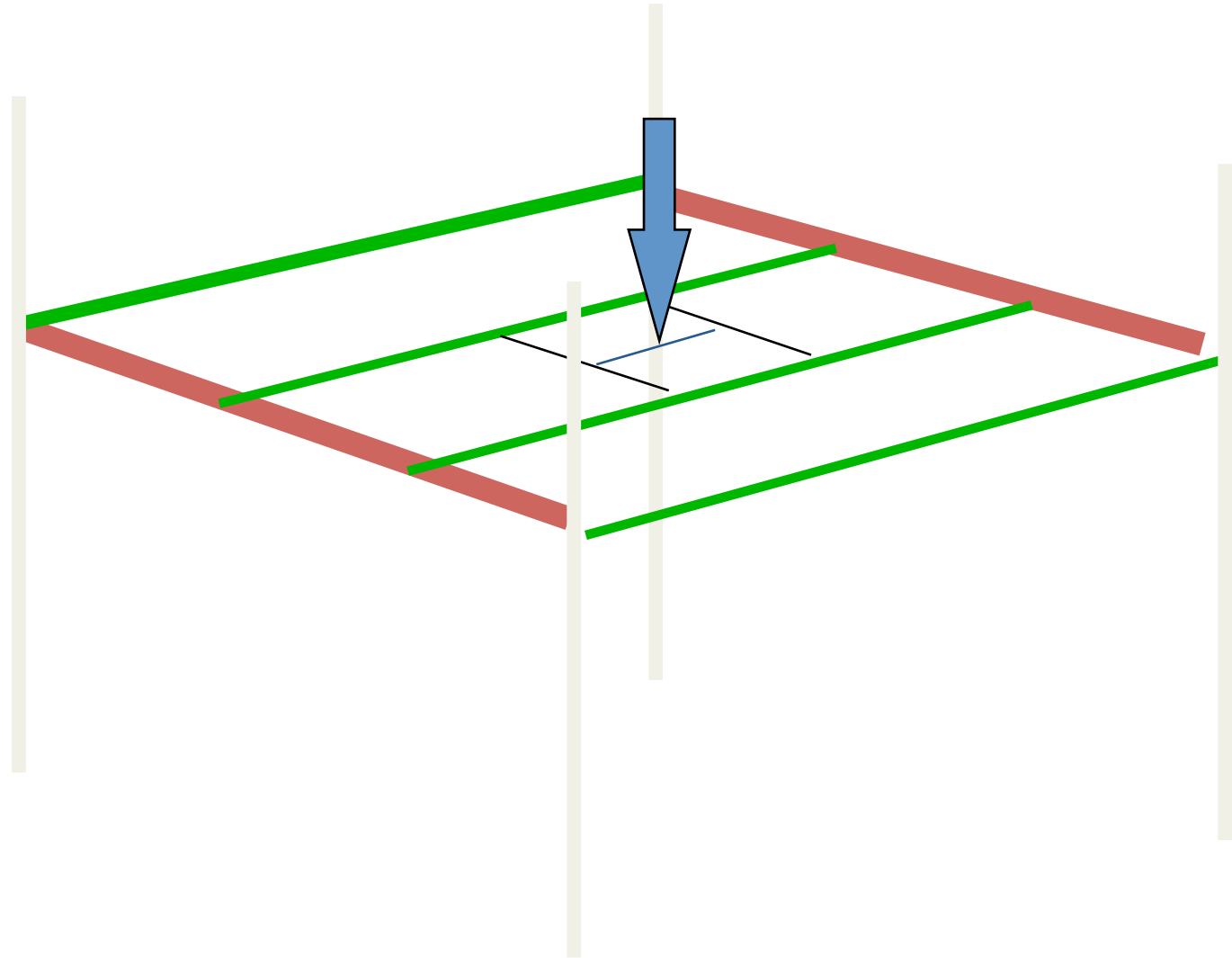

# Structural Components

- Beams
- Girders
- Columns
- Floors
- Foundations

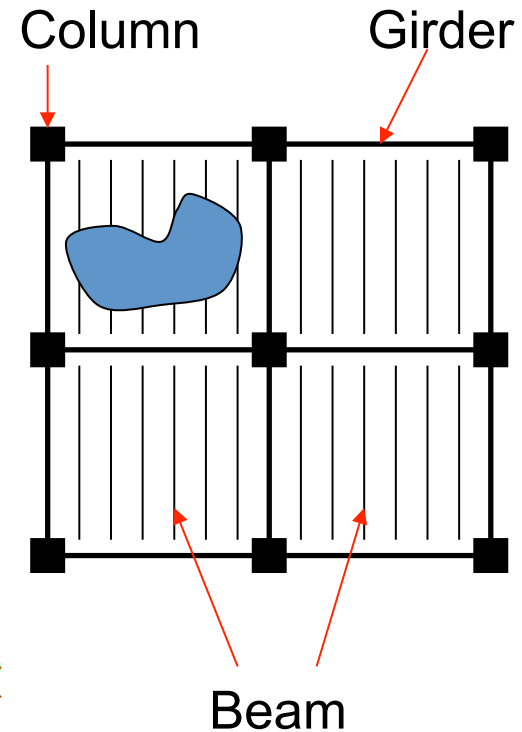
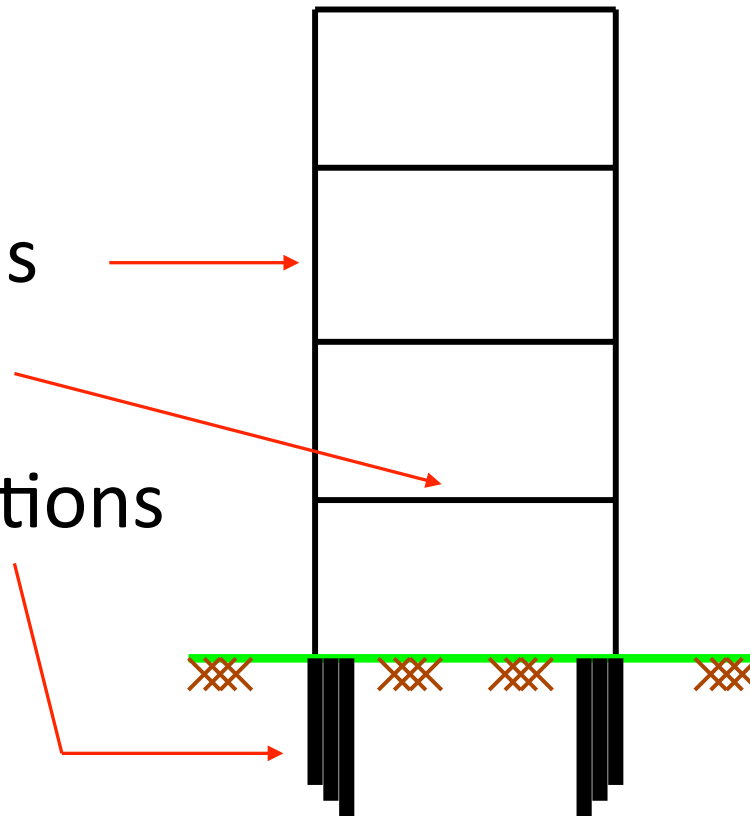

# Load Path

- Floor  
↓
- Beams  
↓
- Girders  
↓
- Columns  
↓
- Foundation  
↓
- Soil/Bedrock

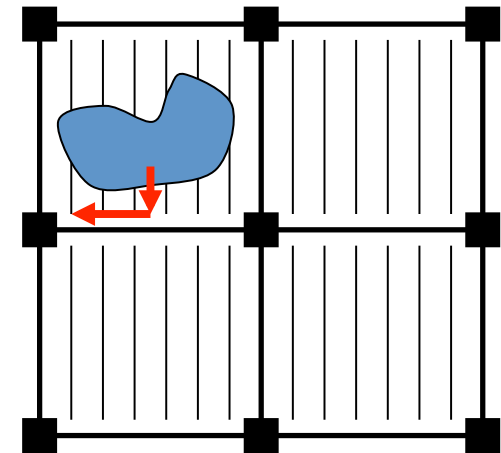
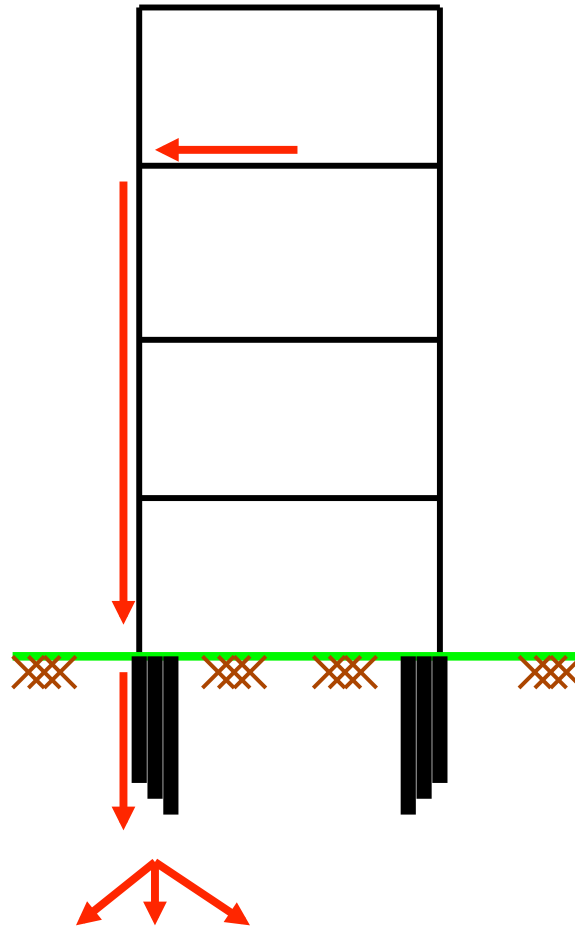

# Flooring

- Composed of a subfloor and floor covering
  - Usually leave space for ductwork, wiring, etc.
  - Floor covering ranges from application to application

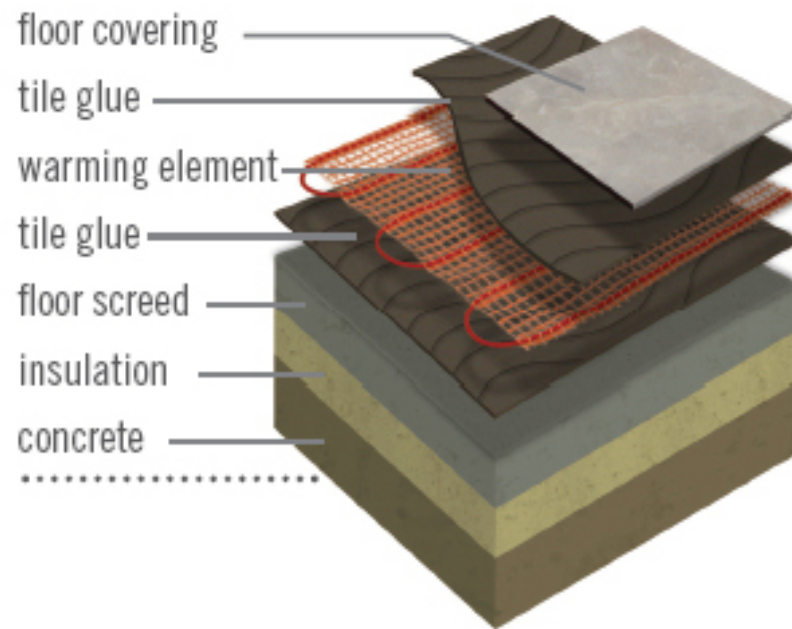

# Beams

- Attached between the girders
  - Take load from the flooring system
  - Transfer it to the girders
  - Generally solid squares, I-beams



# Girders



- Attached column-to-column
  - Take the load from the beams
  - Transfer it to the columns
  - Generally shaped as an I-Beam



# Foundations

- Support the building
  - Typically attached to columns
- Types
  - Shallow
    - Spread footing – concrete strip/pad below the frost line
    - Slab-on-grade – concrete pad on the surface
  - Deep
    - Drilled Shafts
    - Piles

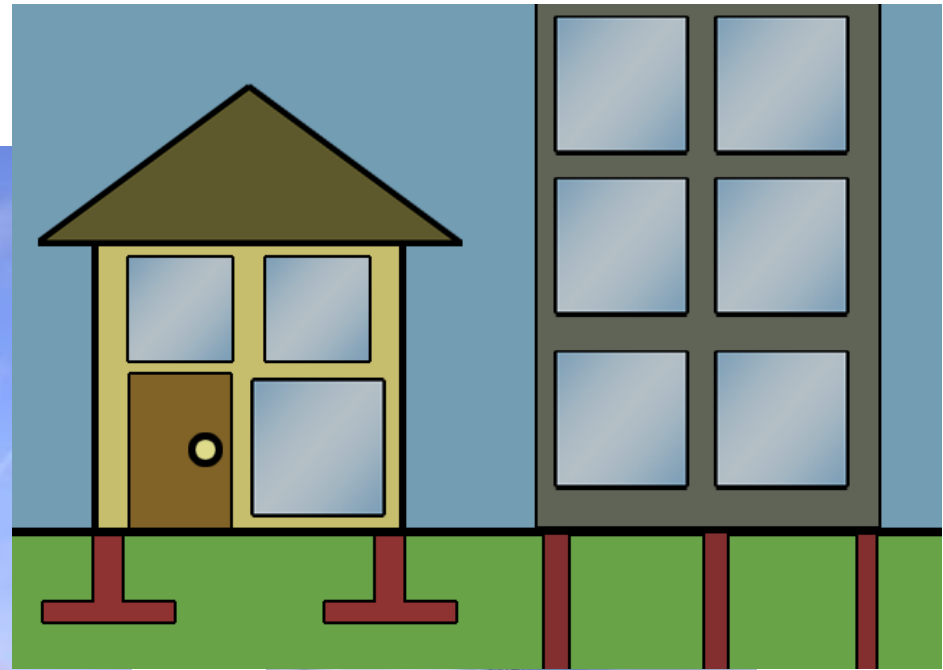

# Overview of Structural Behavior

Depends on:

- Material properties (e.g., steel, concrete).
- Structural stiffness (e.g. axial stiffness, bending stiffness)
- Structural strength (e.g., ultimate member strength).

Design challenges:

- If the structural stiffness is too low, then the displacements will be too large,
- In dynamics applications a high structural stiffness may attract high inertia forces.
- If the structural strength is too low, then the structural system may fail prematurely.

# Axial Stiffness

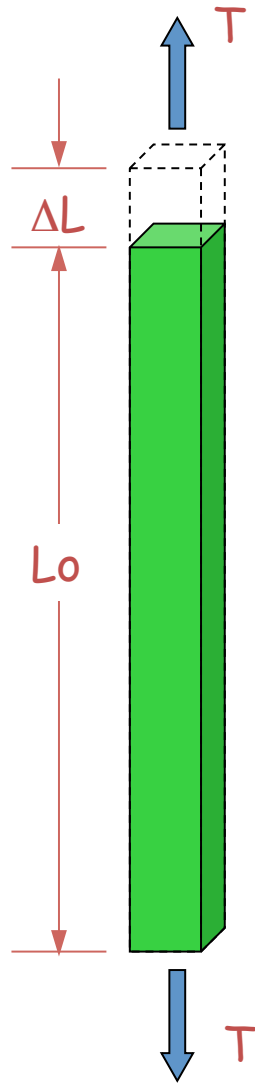

$$\text{Stiffness} = T / \Delta L$$

Example:

$$T = 100 \text{ lb}$$

$$\Delta L = 0.12 \text{ in.}$$

$$\text{Stiffness} = 100 \text{ lb} / 0.12 \text{ in.} = 833 \text{ lb/in.}$$

# Bending Stiffness

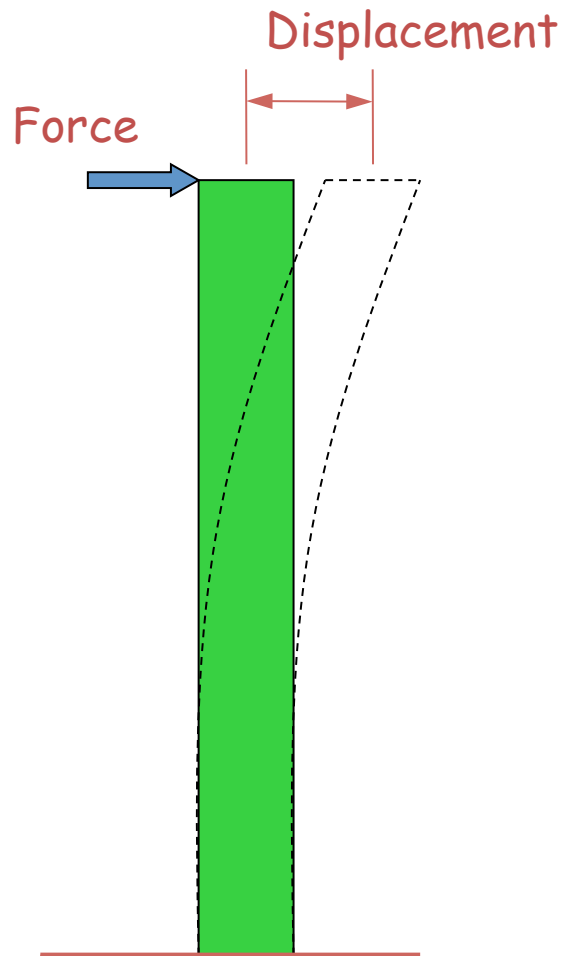

Stiffness = Force / Displacement

Example:

Force = 1,000 lb

Displacement = 0.5 in.

Stiffness = 1,000 lb / 0.5 in. = 2,000 lb/in.

# Definition of Stress

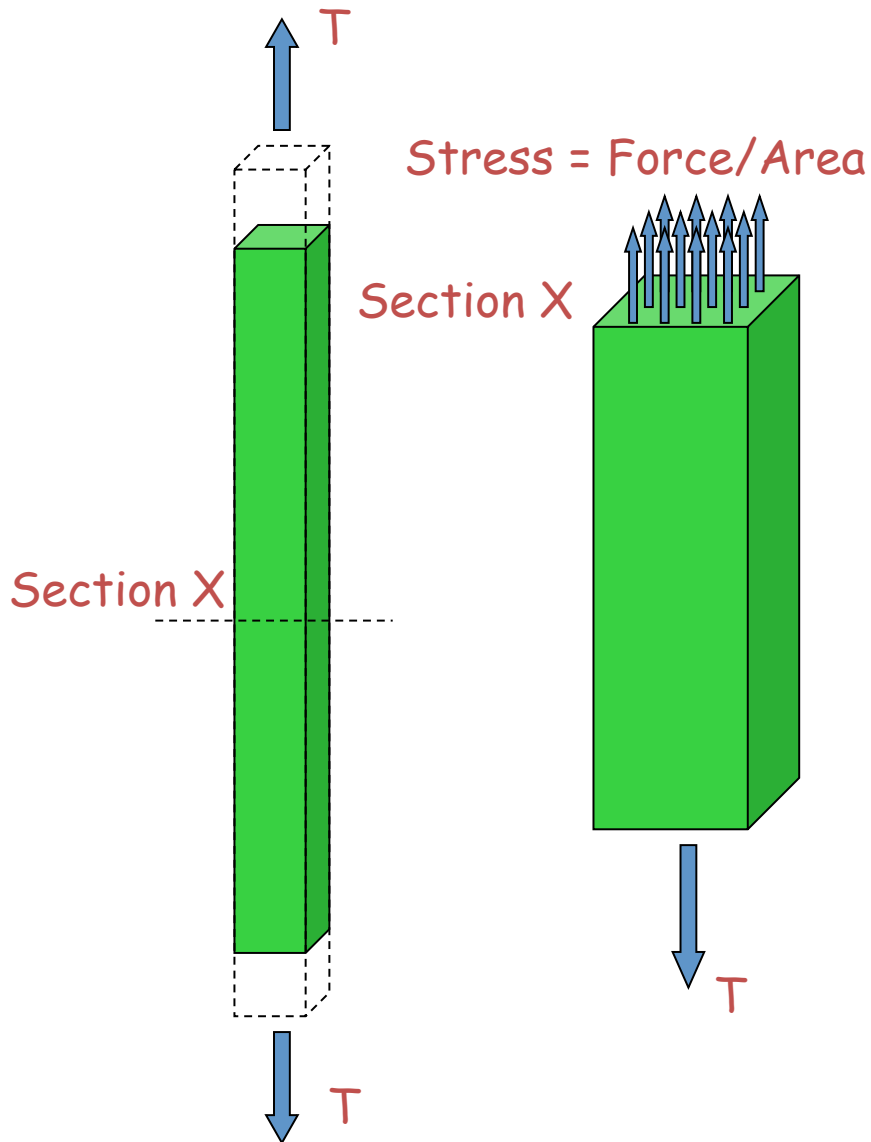

Example (English Units):

$$T = 1,000 \text{ lb (1 kip)}$$

$$A = 10 \text{ in}^2.$$

$$\text{Stress} = 1,000/10 = 100 \text{ lb/in}^2$$

Example (SI Units):

$$1 \text{ lb} = 4.448 \text{ N (Newton)}$$

$$1 \text{ in} = 25.4 \text{ mm}$$

$$T = 1,000 \text{ lb} \times 4.448 \text{ N/lb} = 4448 \text{ N}$$

$$A = 10 \text{ in}^2 \times \frac{(25.4 \text{ mm})^2}{(1 \text{ in})^2} = 6450 \text{ mm}^2$$

$$\text{Stress} = 4448/6450 = 0.69 \text{ N/mm}^2 \text{ (MPa)}$$

# Definition of Strain

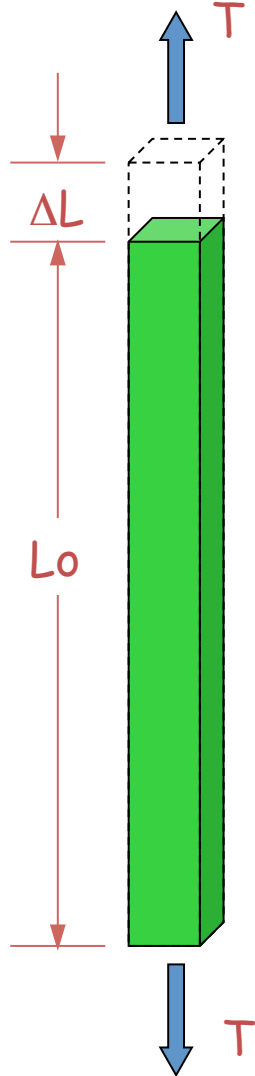

$$\text{Strain} = \Delta L / L_0$$

Example:

$$L_0 = 10 \text{ in.}$$

$$\Delta L = 0.12 \text{ in.}$$

$$\text{Strain} = 0.12 / 10 = 0.012 \text{ in./in.}$$

Strain is dimensionless!!  
(same in English or SI units)

# Stress–Strain Behavior of Elastic Mats.

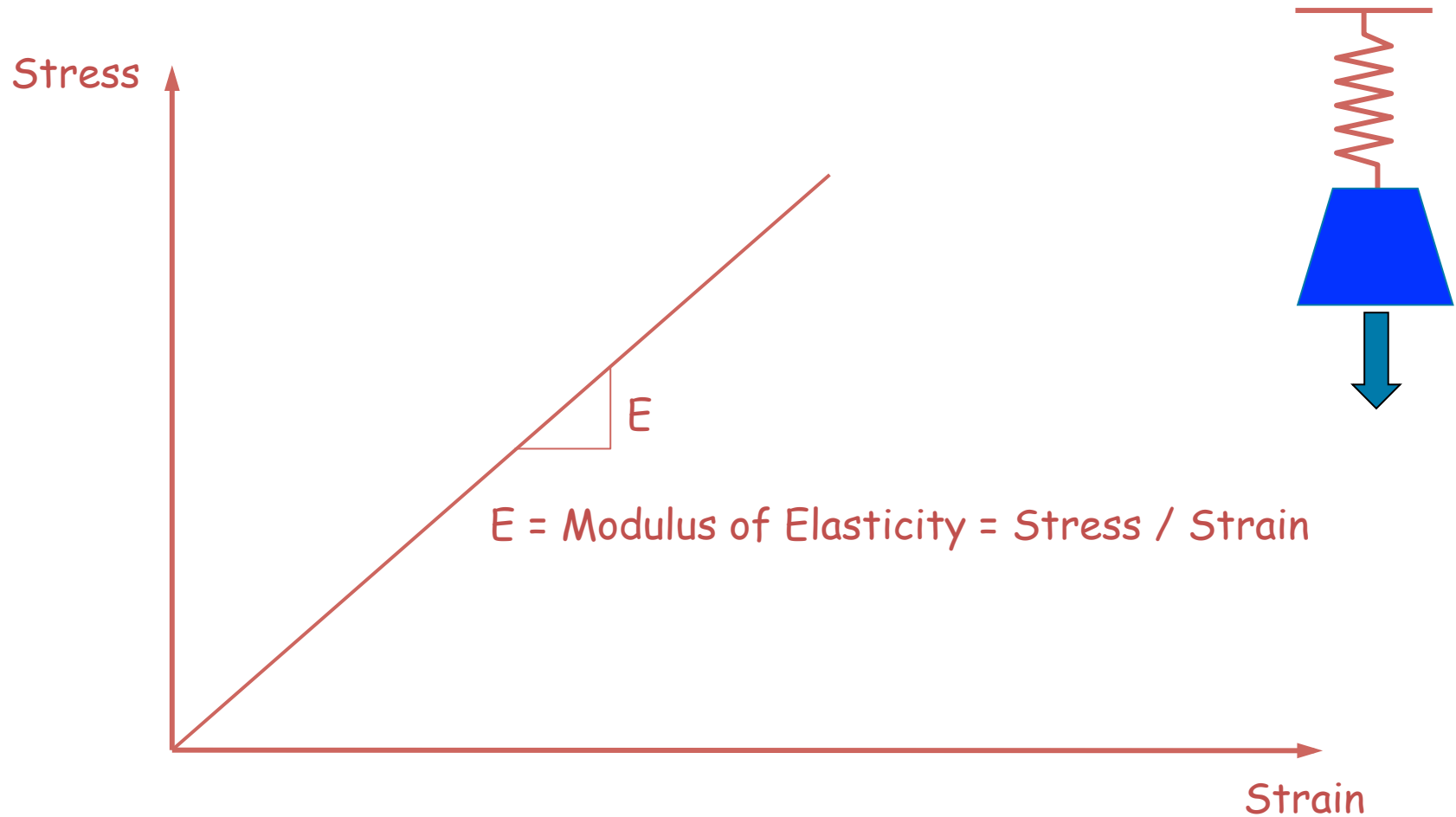



# Types of Stress-Strain Behavior

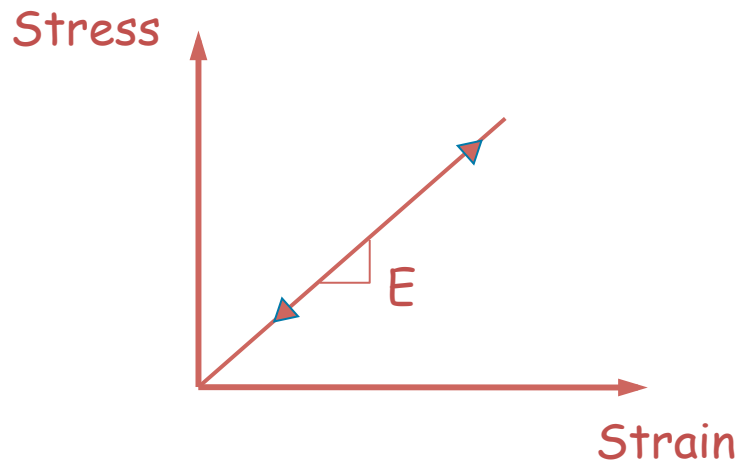

(a) Linear Elastic

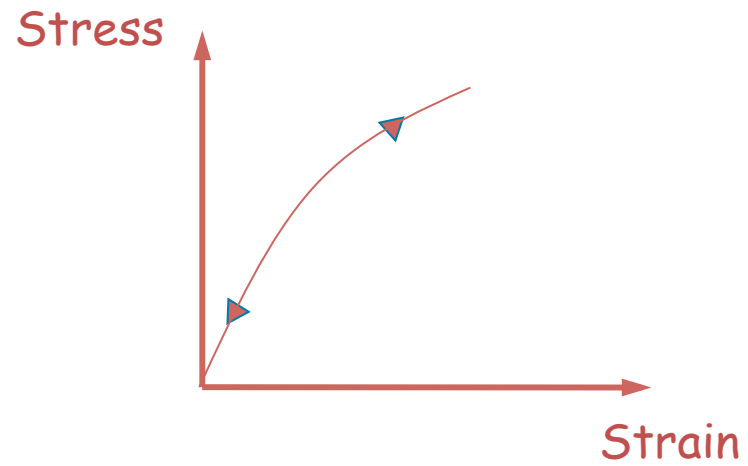

(b) Non-linear Elastic

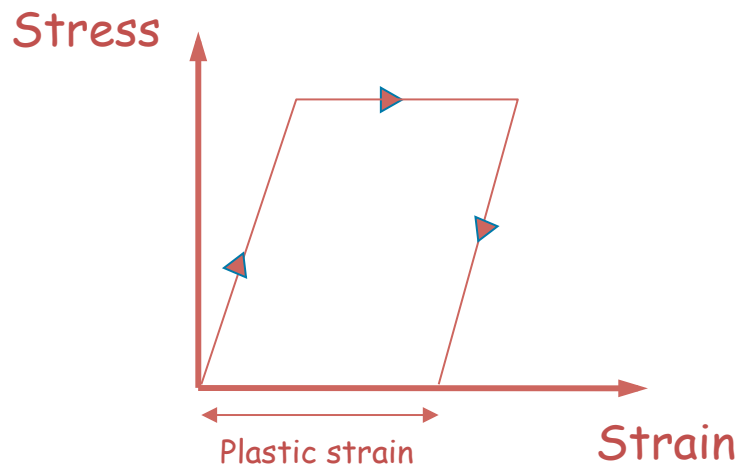

(c) Elastic-plastic

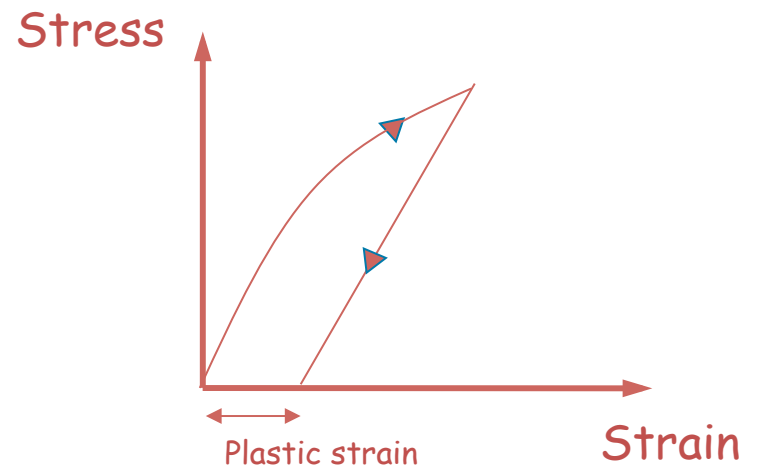

(d) Non-linear Plastic

# Types of Structural Elements – Beams

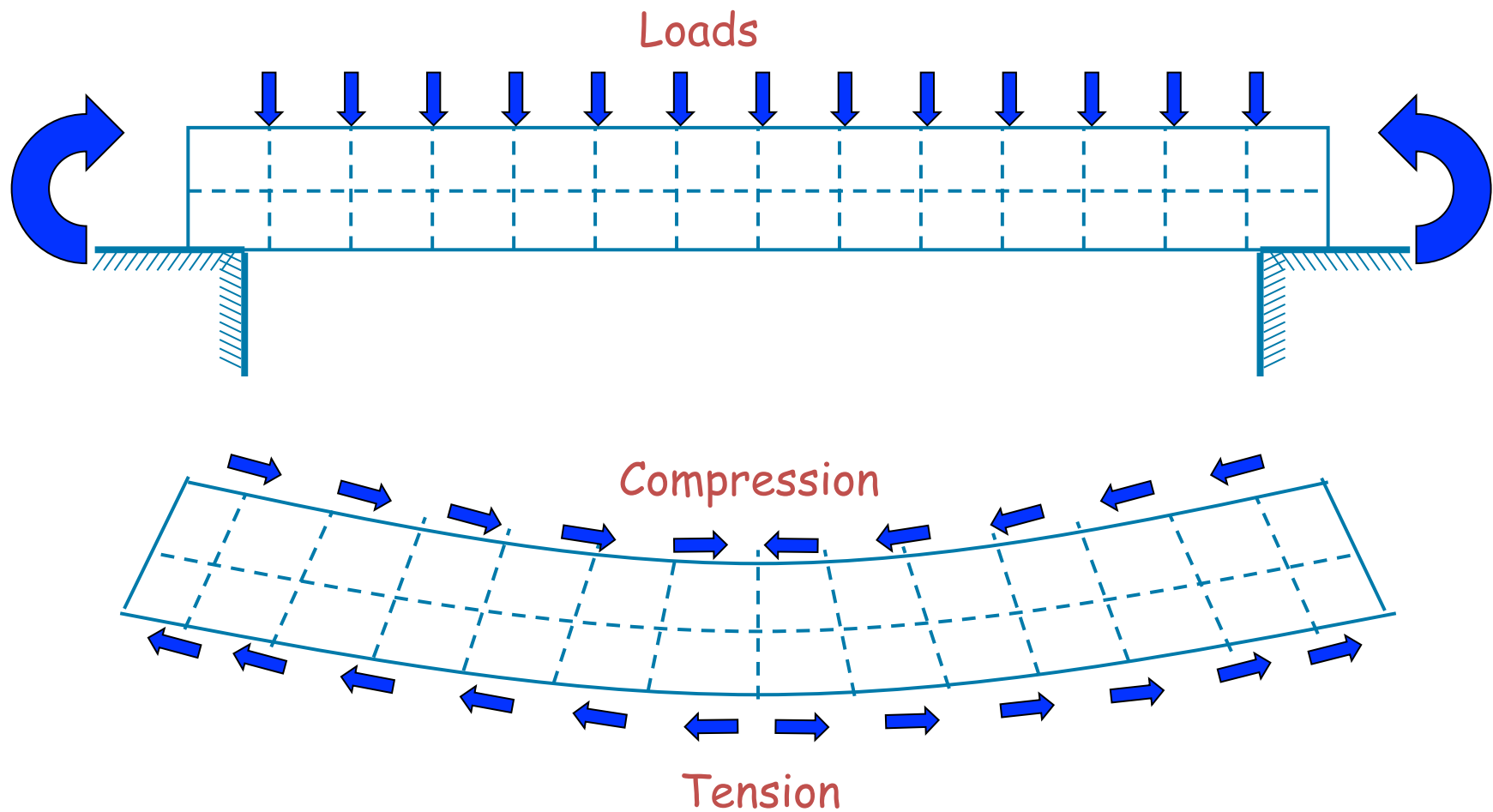

# Engineering Properties of Structural Elements

- Strength

- Ability to withstand a given stress without failure

- Depends on type of material and type of force (tension or compression)

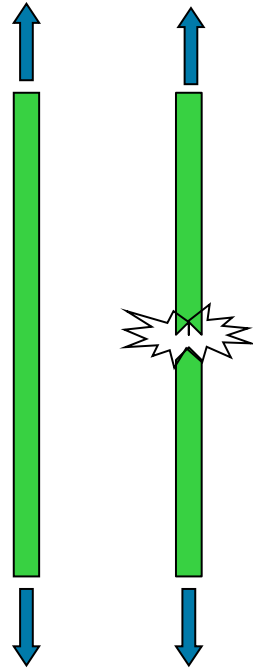

Tensile Failure

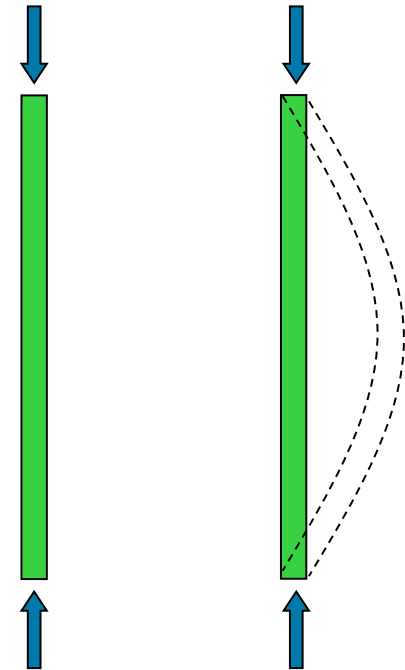

Compressive Failure

# Engineering Properties of Materials

- Steel
  - Maximum stress: 40,000 – 120,000 lb/in<sup>2</sup>
  - Maximum strain: 0.2 – 0.4
  - Modulus of elasticity: 29,000,000 lb/in<sup>2</sup>
- Concrete
  - Maximum stress: 4,000 – 12,000 lb/in<sup>2</sup>
  - Maximum strain: 0.004
  - Modulus of elasticity: 3,600,000 – 6,200,000 lb/in<sup>2</sup>
- Wood
  - Values depend on wood grade. Below are some samples
  - Tension stress: 1300 lb/in<sup>2</sup>
  - Compression stress: 1500 lb/in<sup>2</sup>
  - Modulus of elasticity: 1,600,000 lb/in<sup>2</sup>

## Types of Structural Elements – Bars and Cables

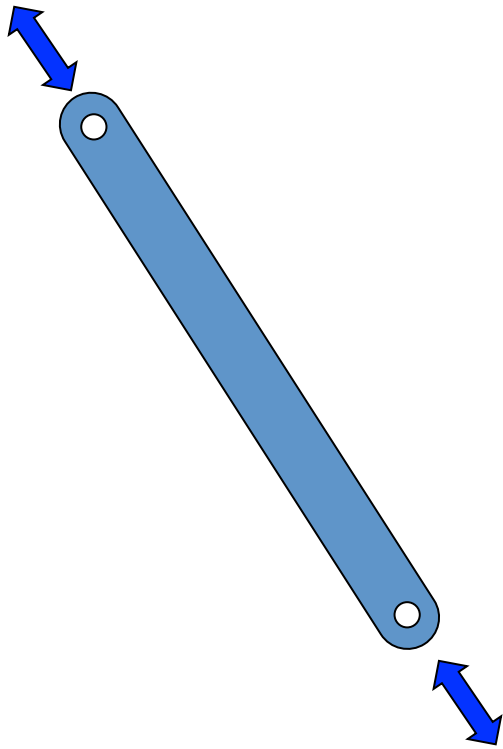

Bars can carry either tension or compression

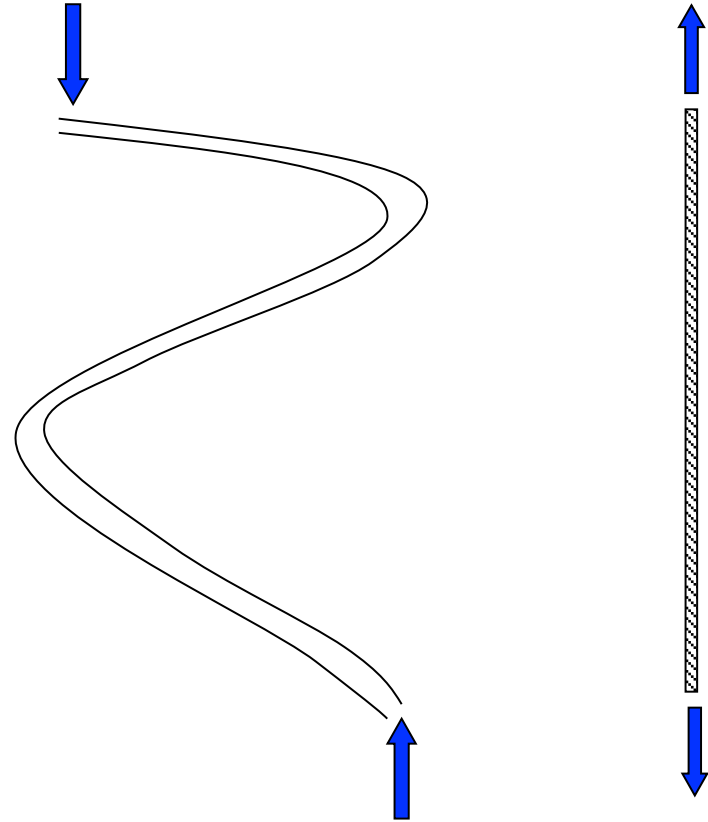

Cables can only carry tension

# Stiffness of Different Structural Shapes

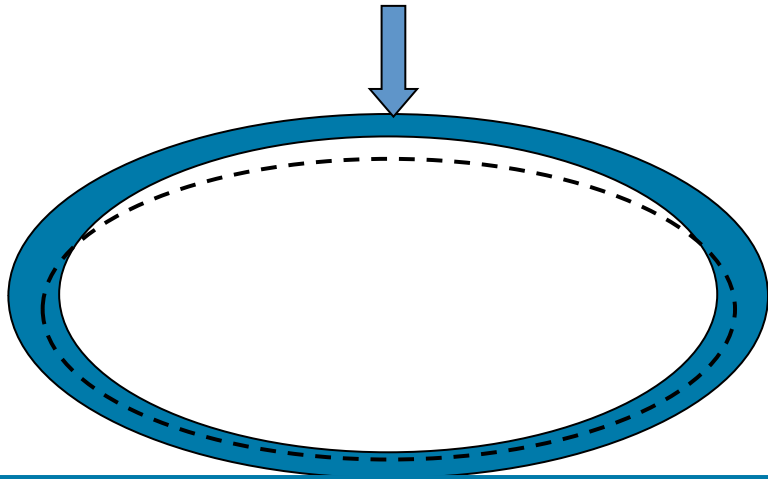

Stiff

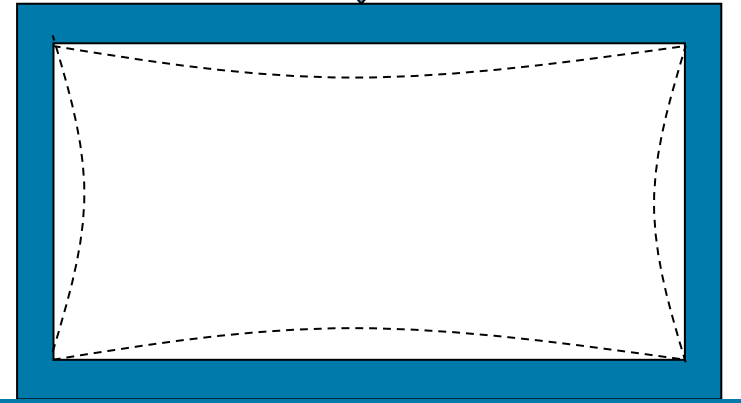

Stiffer

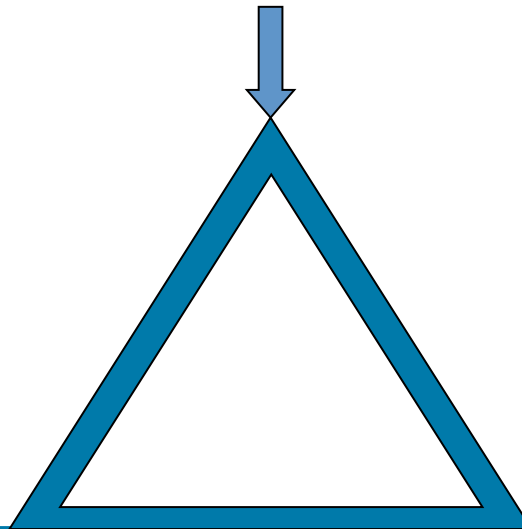

Stiffest

# Providing Stability for Lateral Loads

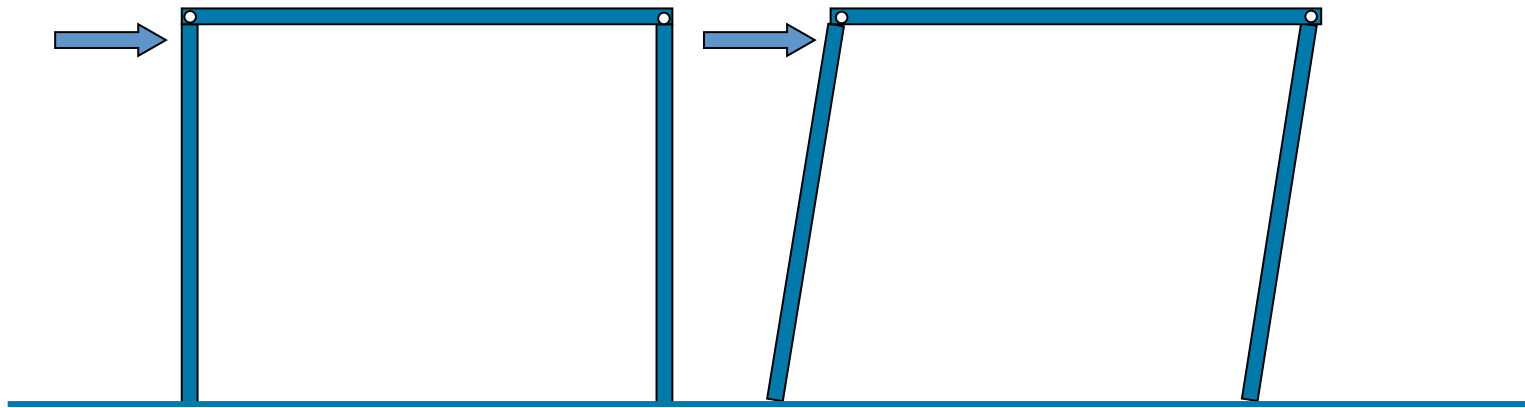

Racking Failure of Pinned Frame

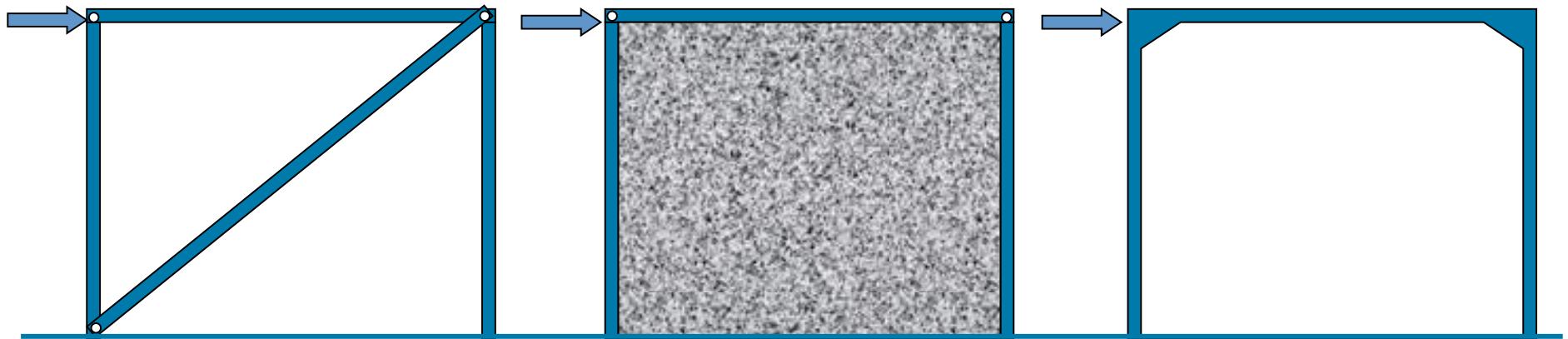

Braced Frame

Infilled Frame

Rigid Joints

# Failure Mechanisms

Structural failure refers to **loss in the load-carrying capacity** of a component or member within a structure.

Failure is initiated when the material is stressed to the strength limit, thus causing fracture or excessive deformations.

Ultimate failure is usually associated with extreme events. The structural engineer needs to **prevent loss of life** by prohibiting total collapse of the structural system.



# Failure due to Dynamic Instability

Failure to understand aeroelastic flutter can be catastrophic.

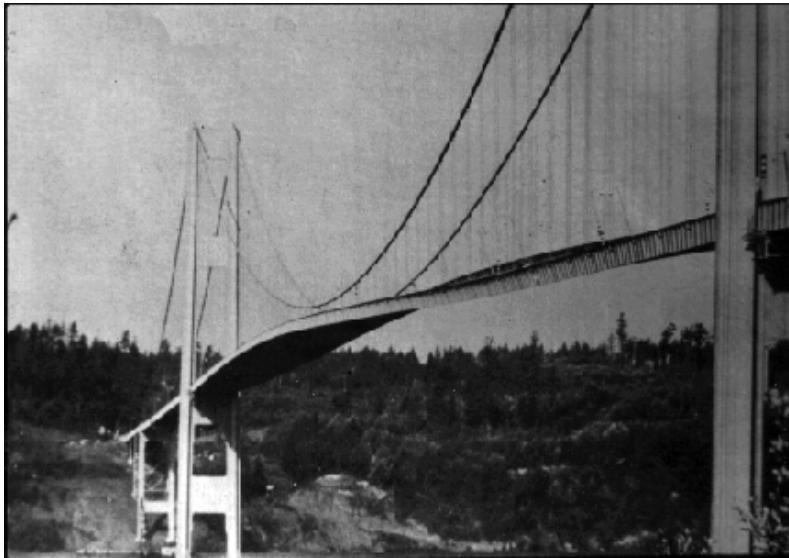

Failure of the Tacoma Narrows bridge completely changed the way in which suspension bridges are analyzed and designed.

# Failure due to neglect ...



Collapsed I35 W. Mississippi Bridge, August 1, 2007.

**Key problems:** lack of funding; poor maintenance.

## Failure due to lack of Ductility in Concrete Columns



**Olive View Hospital  
M 6.7 1971 San Fernando Earthquake**

Frame buildings can have also be built with concrete columns and beams (as opposed to steel)

1971 San Fernando earthquake showed that many concrete frames were brittle

Potential for collapse at drifts of about 0.01 (lower than for steel buildings)

There are thousands of these buildings in California and occupants have not been notified

# Northridge 118 FWY



Example of failure of a brittle concrete column (pre-1975 code)



Example of “ductile” behavior of concrete columns. Although the parking structure performed poorly, the exterior columns did not fail.

## Mexico City Earthquake, 1996

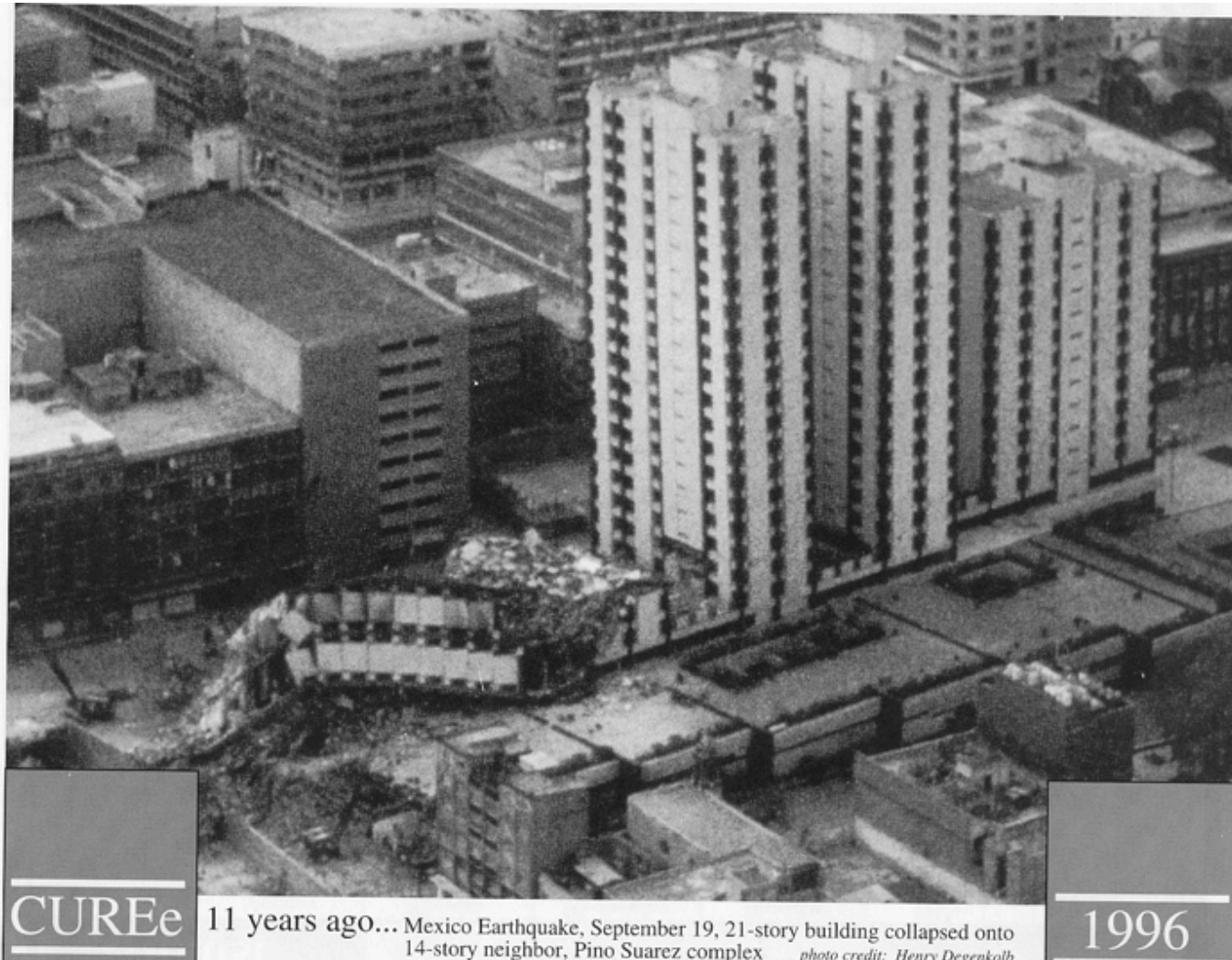

CUREe

11 years ago... Mexico Earthquake, September 19, 21-story building collapsed onto 14-story neighbor, Pino Suarez complex *photo credit: Henry Devenkolb*

1996

## Failure due to liquefaction



CUREe

35 years ago...Niigata, Japan Earthquake, June 16, 1964: Liquefaction and resulting overturning of buildings at the site of an apartment complex in Niigata.

*photo by Joseph Penzien, Steinbrugge Collection/National Information Service for Earthquake Engineering*

1999

Sometimes you are simply in the wrong place at the wrong time ...



Christchurch, New Zealand, 2011.



# Summary

- Structural Engineering:
  - Identifies loads to be resisted
  - Identifies alternatives for providing load paths (arch, truss, frame, ...)
  - Designs structure to provide safe and economical load paths (material, size, connections)
  - To be economical and safe, **we must be able to predict what forces are in structure.**

Acknowledgement: University of Massachusetts Amherst

.