

Chapter 36 Viewgraphs

AC Circuits

Introduction

Most currents and voltages vary in time.

The presence of circuit elements like capacitors and inductors complicates the relation between currents and voltage when these depend on time.

Resistive element

-I&V proportional

$$V(t) = I(t)R$$

Reactive elements

involves derivatives

$$I(t) = C \frac{d}{dt} V_c(t) \quad V_L(t) = L \frac{d}{dt} I(t)$$

Voltage and current are not simply proportional for reactive elements. Ohm's law does not apply.

Three categories of time behavior

1. Direct Current (DC) Voltages and currents are constants in time.
Example: batteries - circuits driven by batteries
2. Transients Voltages and currents change in time after a switch is opened or closed. Changes diminish in time and stop if you wait long enough.

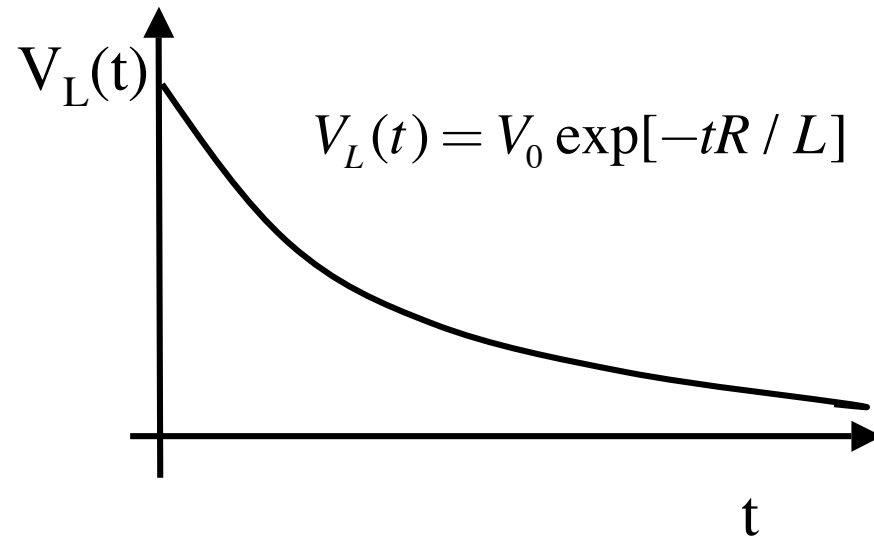
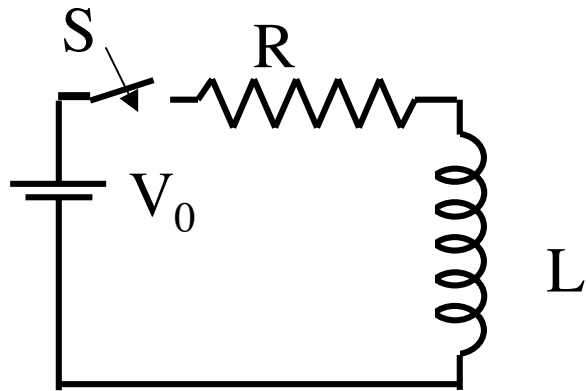

3. Alternating Current (AC). The voltages and currents continually change sinusoidally in time.

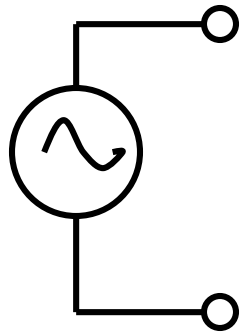

$$V(t) = V_0 \cos[\omega t + \theta]$$

↑ amplitude ↑ phase

frequency

Examples: our power grid when it is on. $f=60$ Hz, $V=110$ V (RMS)

audio signals

communication signals

Power in microwave ovens

Power in MRI machines

Real Life voltages involve DC, AC and Transients

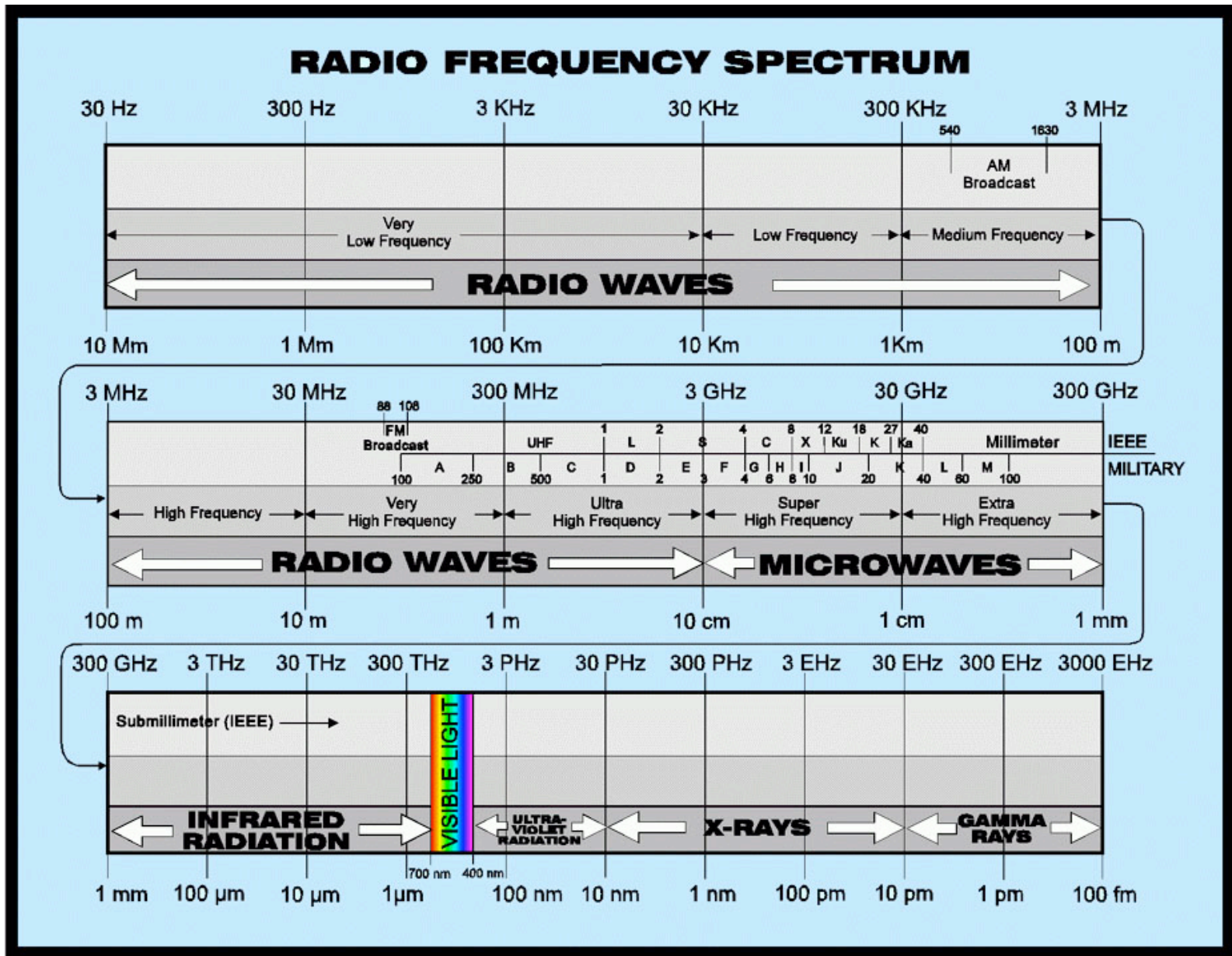

<http://www.tvtower.com/images/rf-spectrum.jpg>

Power Supply: converts AC to DC
Present inside almost all home electronics



Inverter: converts DC to AC
Plugs into cigarette lighter, charges laptop.



Don't run a hair straightener on one of these while driving in your car.

AC - Circuits

First Rule of AC - Circuits - everything oscillates at the same frequency

If a circuit is driven by a source with frequency ω , and you wait for all transients to die out, the circuit will reach a state where every voltage and current is oscillating at the same frequency ω .

Often this is called a “steady state” even though every thing is oscillating.

The problem then becomes: Find the amplitude and phase of each voltage and current.

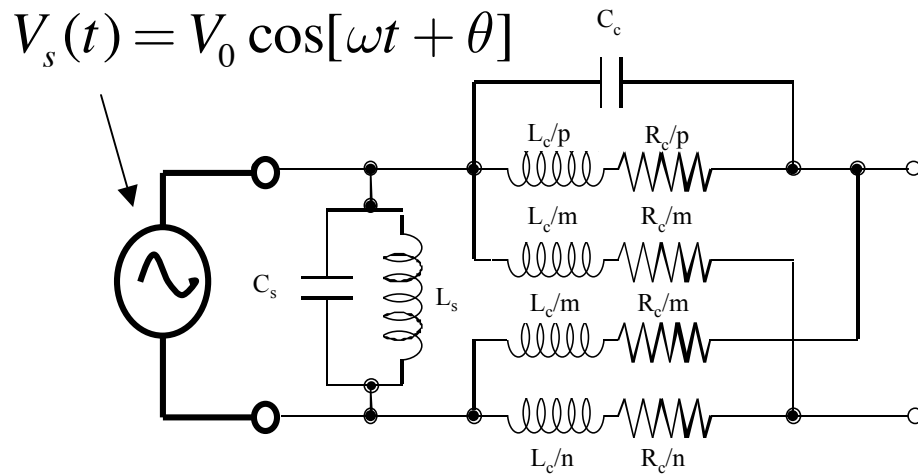

Complicated circuit:
Rs, Ls, and Cs

Every voltage will be in the form

$$V_n(t) = V_{0n} \cos[\omega t + \theta_n]$$

Every current will be in the form

$$I_m(t) = I_{0m} \cos[\omega t + \theta_m]$$

Problem is to find the amplitudes and phases

Some general comments about circuits driven by a source with frequency ω .

$$V_s(t) = V_0 \cos[\omega t + \theta]$$

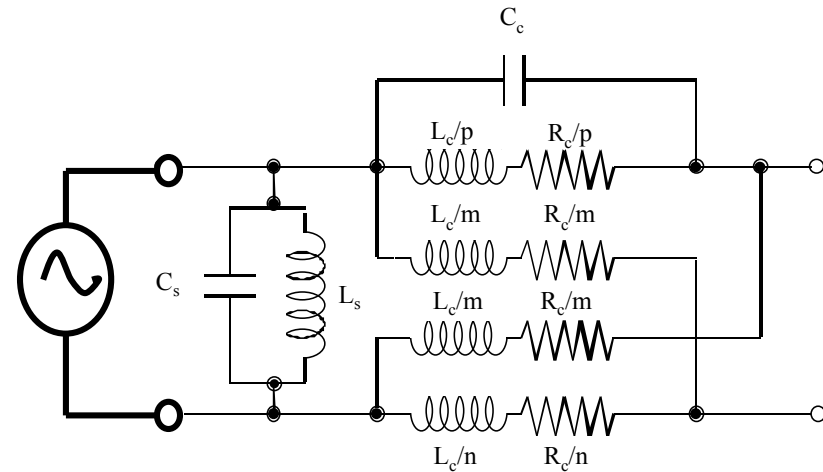

1. All voltages and currents oscillate at the same frequency ω .
2. Amplitudes and phases of voltages and currents depend on source and R_s , C_s , L_s , and ω .
3. Amplitudes of voltages and currents are proportional to source voltage.
4. Phases of voltages and currents do not depend on amplitude of source voltage.
5. Shifting the phase of the source shifts the phase of all voltages and currents by the same amount.

Let's do a "simple" example

$$V_s(t) = V_0 \cos[\omega t + \theta_s]$$

Can take: $\theta_s = 0$

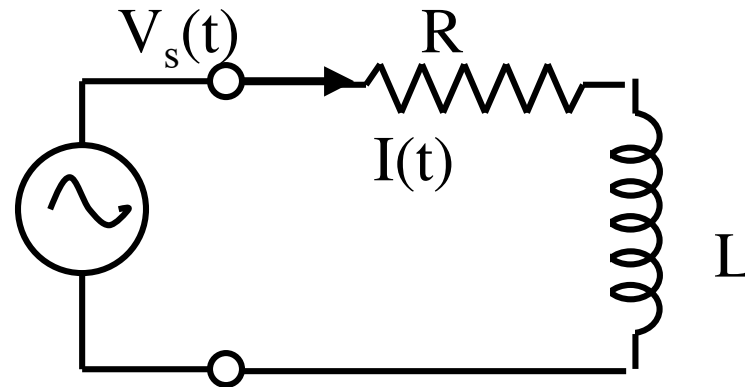

Current I , flows through both R and L $I(t) = I_0 \cos[\omega t + \theta_I]$

Resistor Voltage $V_R = RI(t) = RI_0 \cos[\omega t + \theta_I]$

Inductor Voltage

$$V_L = L \frac{d}{dt} I(t) = -\omega LI_0 \sin[\omega t + \theta_I] = \omega LI_0 \cos[\omega t + \theta_I + \frac{\pi}{2}]$$

Inductor voltage is 90 degrees out of phase with resistor voltage and current

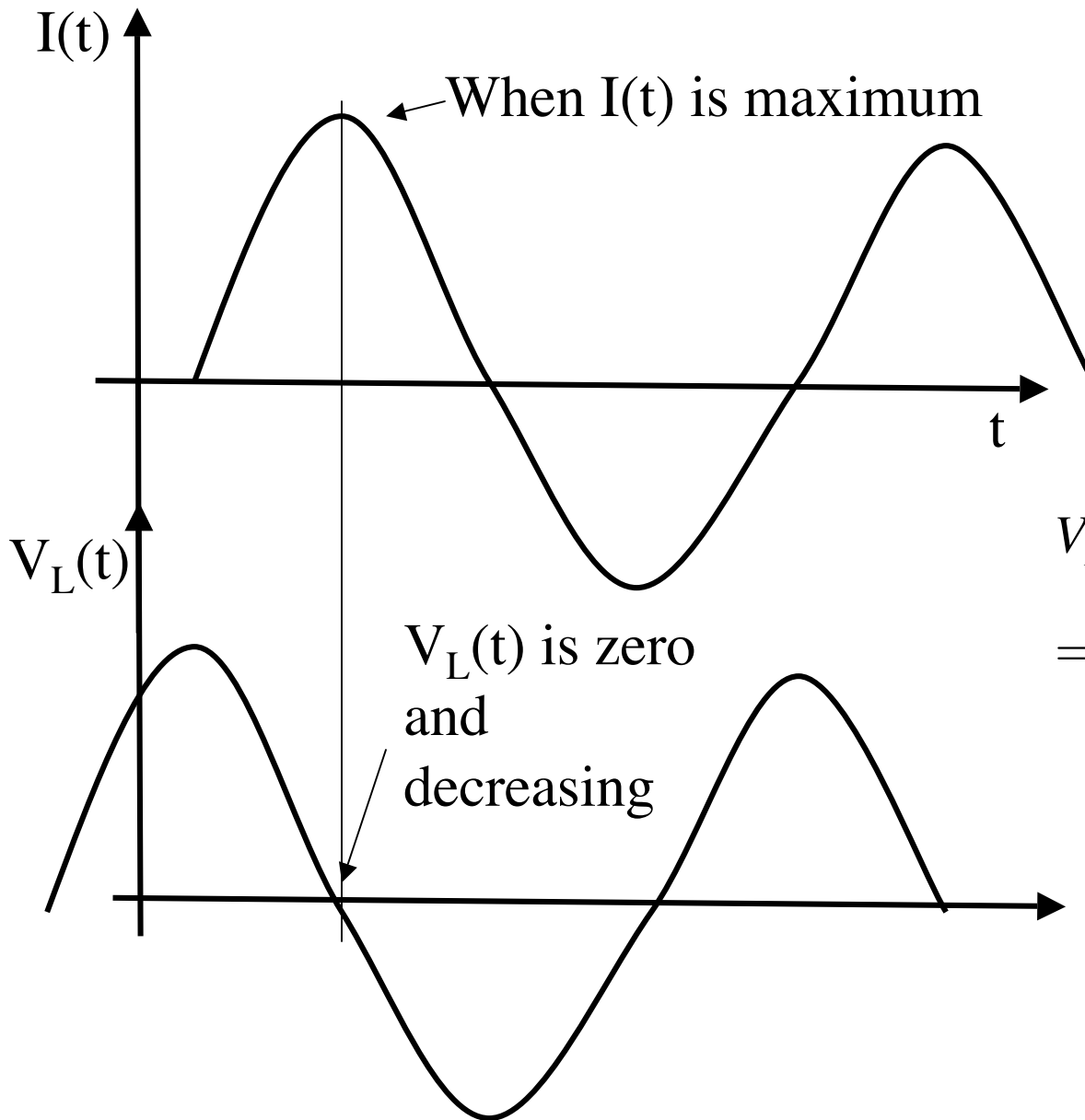

$$I(t) = I_0 \cos[\omega t + \theta_I]$$

$$V_L = -\omega L I_0 \sin[\omega t + \theta_I]$$

$$= \omega L I_0 \cos[\omega t + \theta_I + \frac{\pi}{2}]$$

V_L leads I by $\pi/2$

Which could be true?

- a. Red is the voltage across an inductor, black is the current through that inductor
- b. Black is the voltage across an inductor, red is the current through that inductor
- c. neither of the above

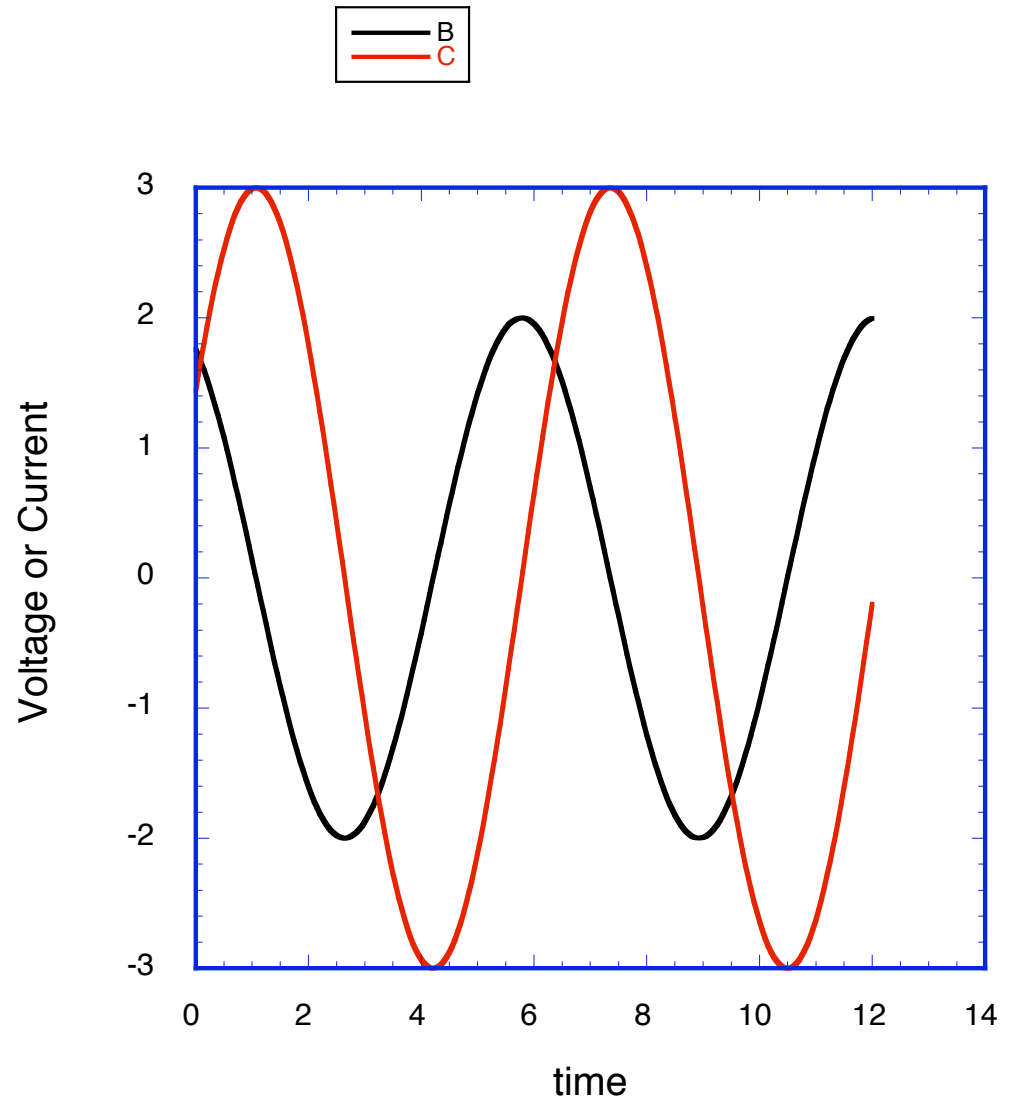

Which could be true?

- a. Red is the voltage across a capacitor, black is the current through that capacitor
- b. Black is the voltage across a capacitor, red is the current through that capacitor
- c. neither of the above

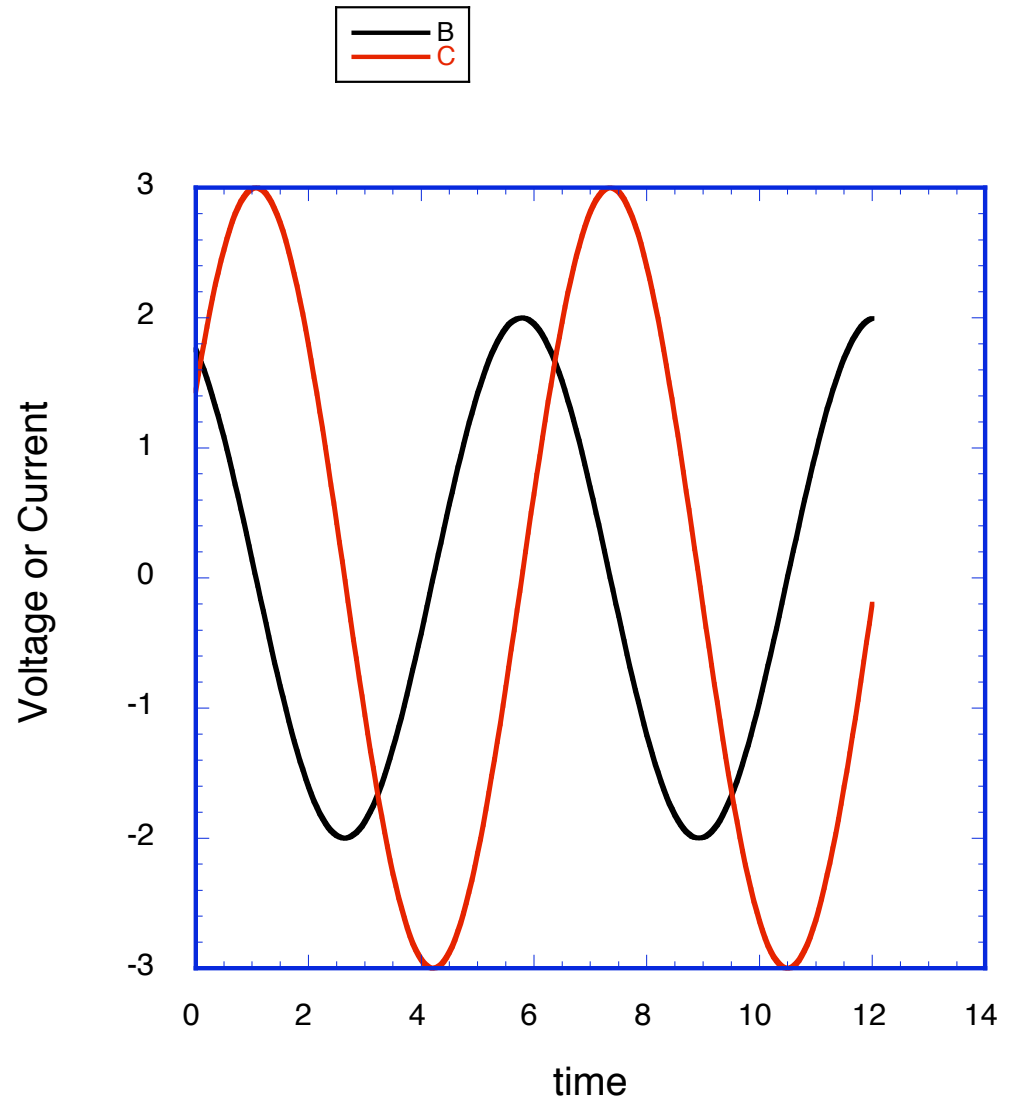

Let's do a "simple" example

$$V_s(t) = V_0 \cos[\omega t + \theta_s]$$

Can take: $\theta_s = 0$

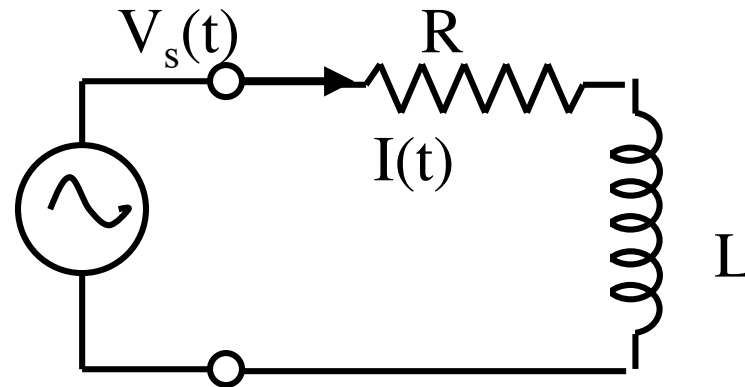

Current I , flows through both R and L $I(t) = I_0 \cos[\omega t + \theta_I]$

Resistor Voltage $V_R = RI(t) = RI_0 \cos[\omega t + \theta_I]$

Inductor Voltage

$$V_L = L \frac{d}{dt} I(t) = -\omega LI_0 \sin[\omega t + \theta_I] = \omega LI_0 \cos[\omega t + \theta_I + \frac{\pi}{2}]$$

Inductor voltage is 90 degrees out of phase with resistor voltage and current

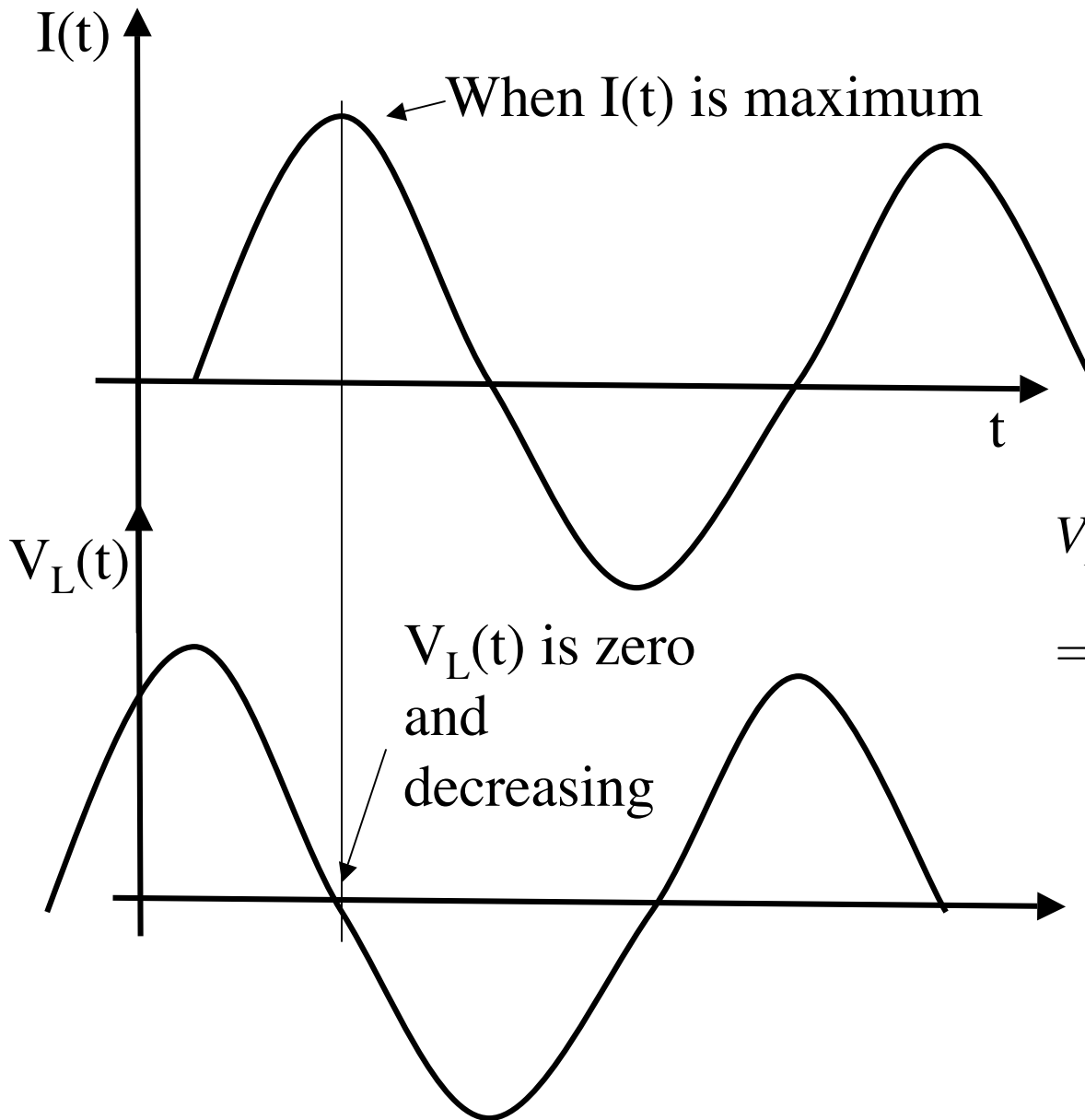

$$I(t) = I_0 \cos[\omega t + \theta_I]$$

$$V_L = -\omega L I_0 \sin[\omega t + \theta_I]$$

$$= \omega L I_0 \cos[\omega t + \theta_I + \frac{\pi}{2}]$$

V_L leads I by $\pi/2$

Kirchoff's Voltage Law: sum of voltages around loop=0 for all t

$$V_s(t) = V_R(t) + V_L(t)$$
$$V_0 \cos[\omega t] = RI_0 \cos[\omega t + \theta_I] - \omega LI_0 \sin[\omega t + \theta_I]$$

Find

How to solve:

1. Use trigonometric identities

$$\cos[\omega t + \theta_I] = \cos[\omega t] \cos[\theta_I] - \sin[\omega t] \sin[\theta_I]$$

$$\sin[\omega t + \theta_I] = \sin[\omega t] \cos[\theta_I] + \cos[\omega t] \sin[\theta_I]$$

2. Collect terms multiplying $\sin[\omega t]$ and $\cos[\omega t]$

After regrouping

“Reactance” $X_L = \omega L$

$$V_0 \cos[\omega t] = \cos[\omega t](R \cos \theta_I - X_L \sin \theta_I) I_0 \\ - \sin[\omega t](R \sin \theta_I + X_L \cos \theta_I) I_0$$

Can only be satisfied for all t if coefficients of **cos** and **sin** are separately equal.

$$V_0 = (R \cos \theta_I - X_L \sin \theta_I) I_0$$

$$0 = (R \sin \theta_I + X_L \cos \theta_I)$$

Solution:

$$\tan \theta_I = -X_L / R$$

$$I_0 = V_0 / \sqrt{R^2 + X_L^2}$$

Solution: $I_0 = V_0 / \sqrt{R^2 + X_L^2}$ $\tan \theta_I = -X_L / R$ $X_L = \omega L$

Inductor voltage $V_L = V_0 \frac{X_L}{\sqrt{R^2 + X_L^2}} \cos[\omega t + \theta_I + \frac{\pi}{2}]$

Resistor Voltage $V_R = V_0 \frac{R}{\sqrt{R^2 + X_L^2}} \cos[\omega t + \theta_I]$

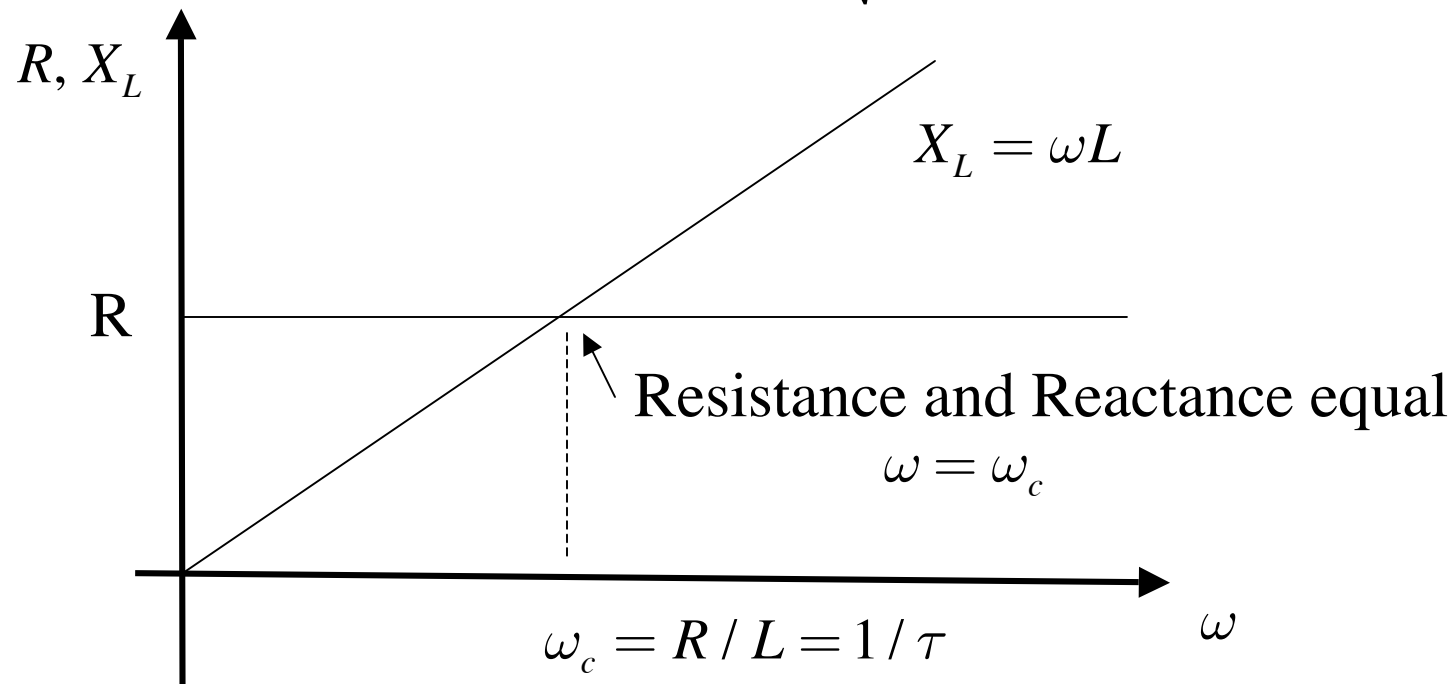

Crossover network

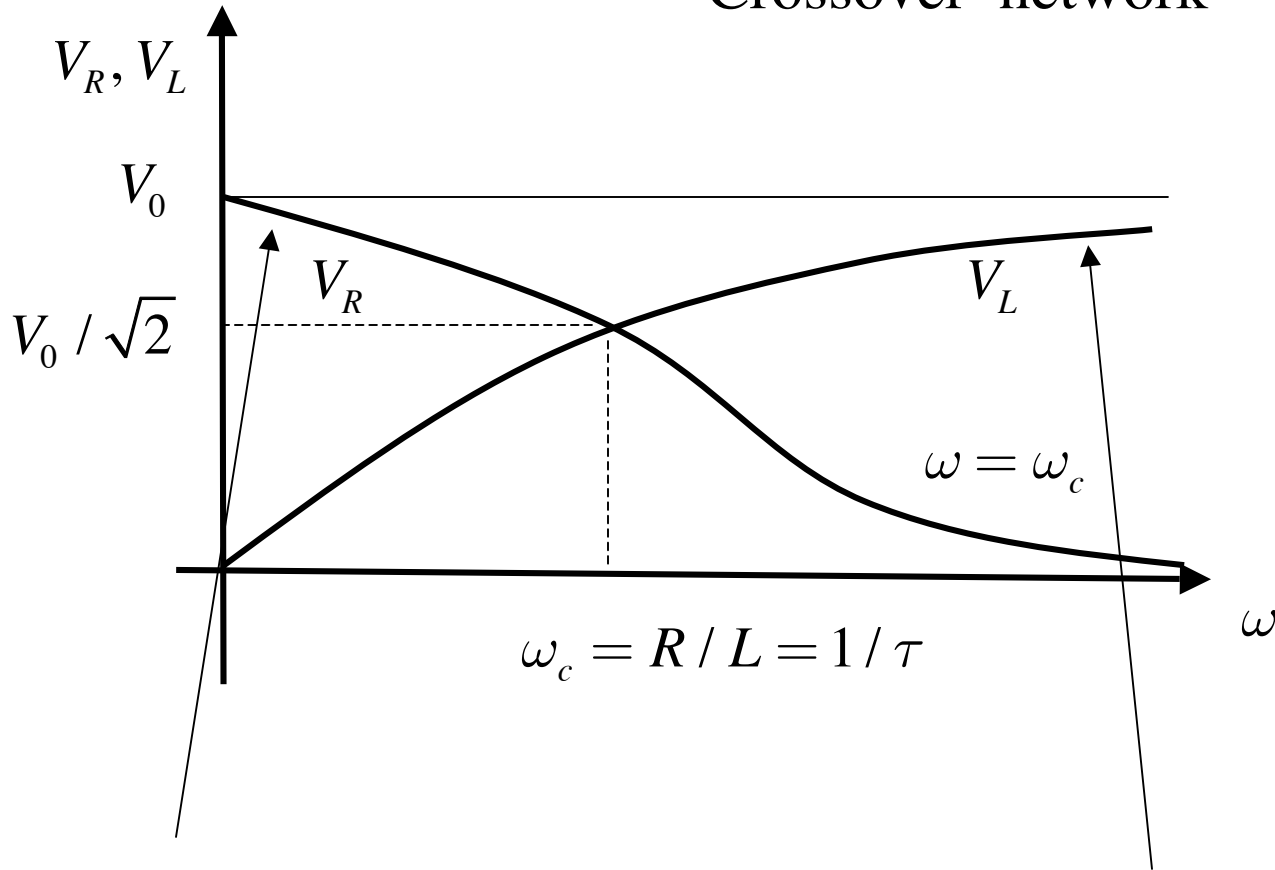

Low frequency
Inductor is short
All voltage appears
across resistor

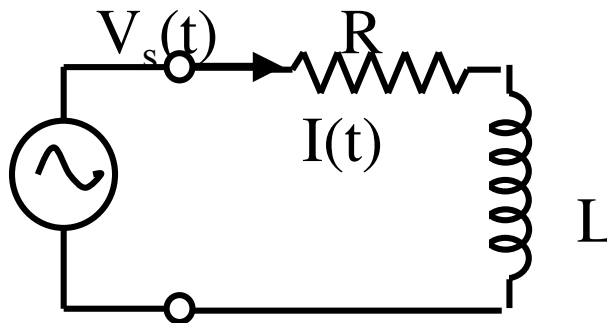

High frequency
Inductor is open
All voltage appears
across inductor

Recall for a moment when life was simple - DC circuits.

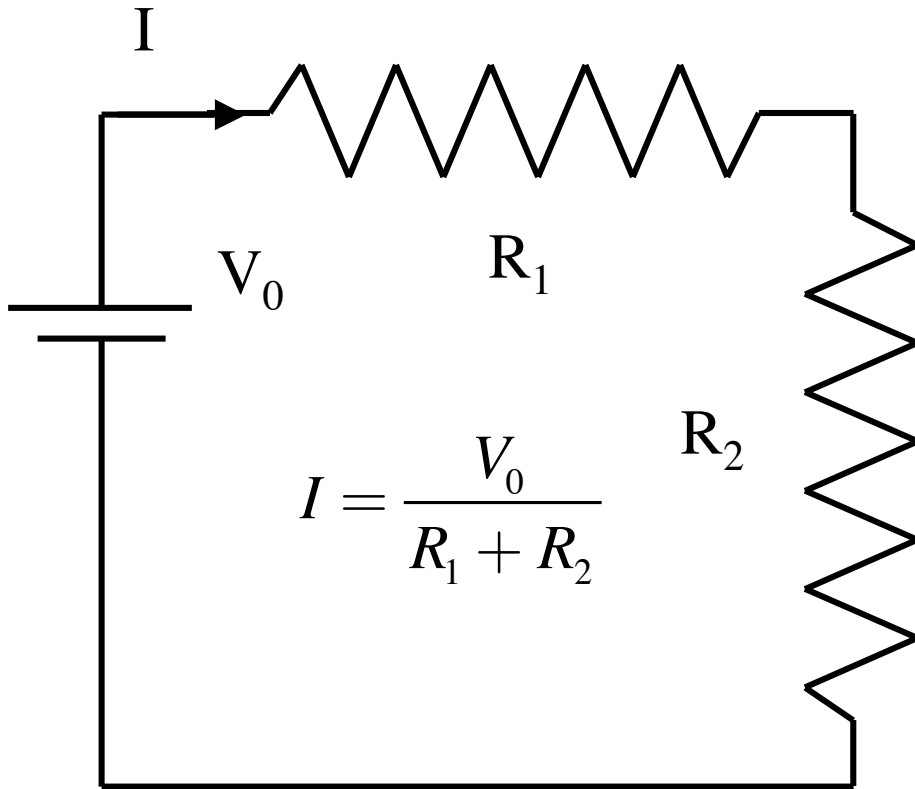

Wouldn't you do anything to get back to that simple way of analyzing circuits?

- A. Yes
- B. No
- C. What do you mean by anything?

Phasors: sinusoidal signals can be represented as vectors rotating in a plane. Later we will see that this is the complex plane

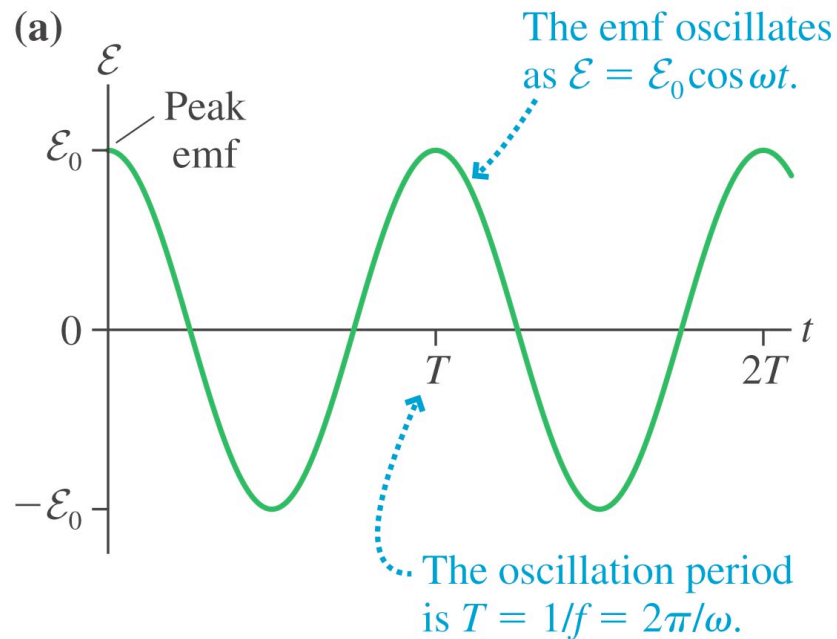

Copyright © 2008 Pearson Education, Inc., publishing as Pearson Addison-Wesley.

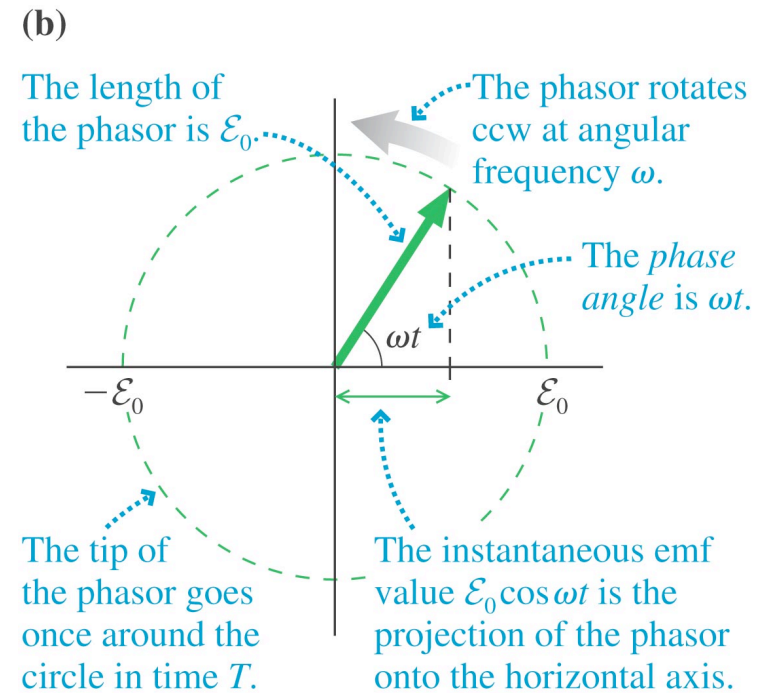

Copyright © 2008 Pearson Education, Inc., publishing as Pearson Addison-Wesley.

Think of the time dependent voltage as the projection of the rotating vector on to the horizontal axis

What are the phasors for the voltages in our circuit?

$$V_L = V_0 \frac{X_L}{\sqrt{R^2 + X_L^2}} \cos\left[\omega t + \theta_I + \frac{\pi}{2}\right]$$

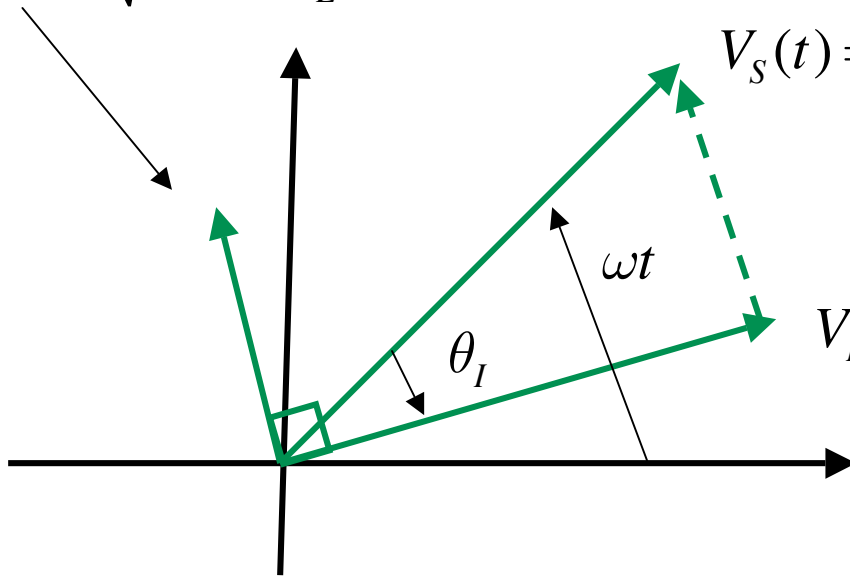

$$V_S(t) = V_0 \cos[\omega t]$$

$$\tan \theta_I = -X_L / R$$

$$V_R = V_0 \frac{R}{\sqrt{R^2 + X_L^2}} \cos[\omega t + \theta_I]$$

$V_R(t)$ and $V_L(t)$ form two sides of a right triangle, the hypotenuse is $V_s(t)$



The magnitude of the instantaneous value of the emf represented by this phasor is

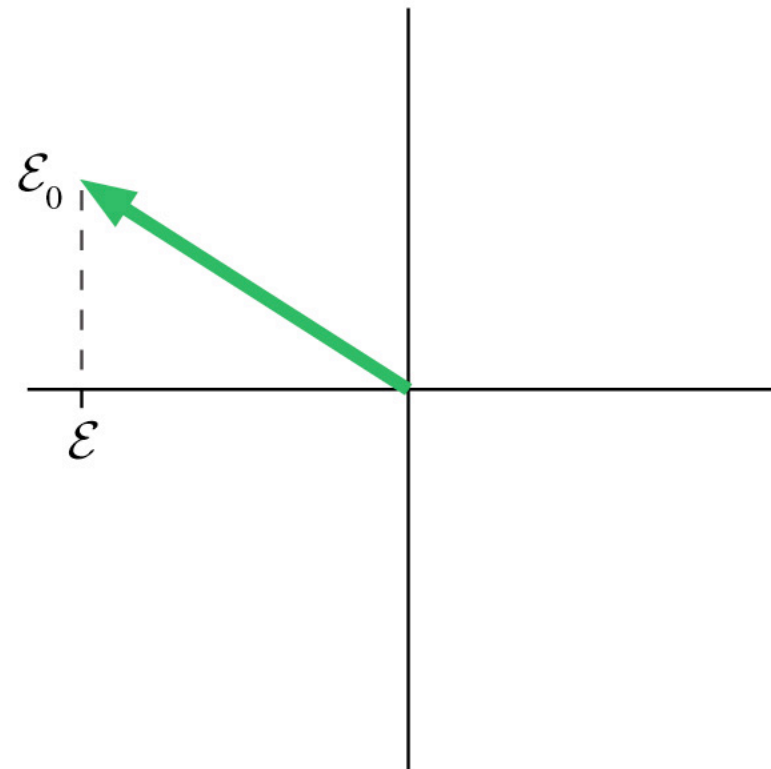

- A. constant.
- B. increasing.
- C. decreasing.
- D. It's not possible to tell without knowing t .

Bottom Line

Everything you learned about DC circuits can be applied to AC circuits provided you do the following:

1. Replace all voltages and currents by their complex phasor amplitudes. In practice this means putting a hat on each letter.
2. Treat inductors as resistors with “resistance” $j\omega L$
3. Treat capacitors as resistors with “resistance” $1/(j\omega C)$

$$j = \sqrt{-1}$$

Phasors - a way of representing complex numbers

Imaginary number $j = \sqrt{-1}$ Engineers use j
Physicists and mathematicians use i

Complex number $Z = X + jY$ X is the real part
Y is the imaginary part

Complex numbers follow the same rules of algebra as regular numbers

$$Z_1 = X_1 + jY_1 \quad Z_2 = X_2 + jY_2$$

Addition: $Z_1 + Z_2 = (X_1 + X_2) + j(Y_1 + Y_2)$

Multiplication:

$$Z_1 Z_2 = (X_1 + jY_1)(X_2 + jY_2) = X_1 X_2 + j^2 Y_1 Y_2 + j(X_1 Y_2 + X_2 Y_1)$$

-1



A complex number is specified by two real numbers

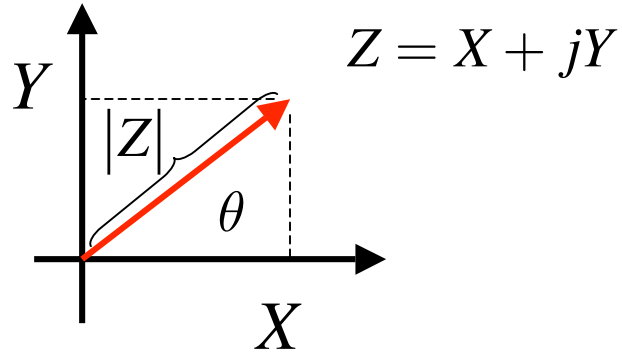

$$Z = X + jY$$

Instead of real and imaginary parts can give magnitude and phase

$$|Z| = \sqrt{X^2 + Y^2}$$

$$\tan \theta = Y / X$$

Multiplying complex numbers - part 2

Magnitudes multiply

Phases add

$$Z_3 = Z_1 Z_2$$

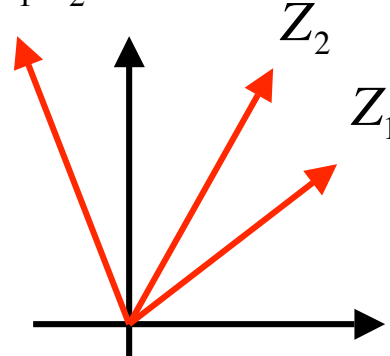

$$|Z_3| = |Z_1| |Z_2|$$

$$\theta_3 = \theta_1 + \theta_2$$

Exponential
function

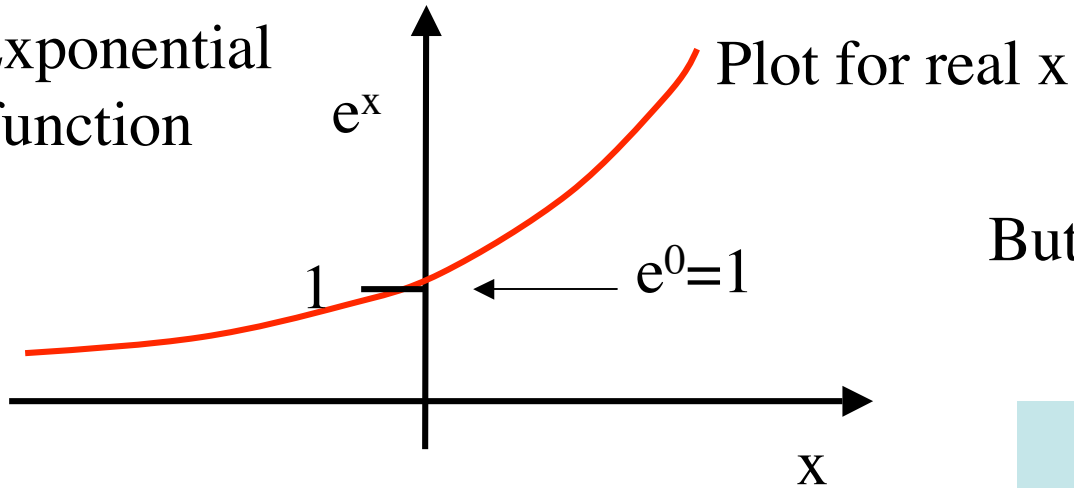

But, what if x is imaginary?

$$e^{j\theta} = \cos \theta + j \sin \theta$$

Let $X = \cos \theta$, $Y = \sin \theta$
 $Z = \cos \theta + j \sin \theta$

Then you can show:

$$\frac{dZ}{d\theta} = jZ$$

So: $Z(\theta) = Z(0)e^{j\theta} = e^{j\theta}$

$$Z(0) = 1 + j0 = 1$$

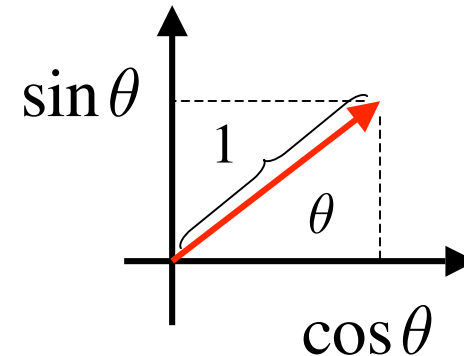

Phasors

Suppose I have an oscillating voltage $V(t) = V_0 \cos[\omega t + \theta]$

I can write this as the real part of a complex number.

$$V(t) = \text{Re}[(V_0 e^{j\theta}) e^{j\omega t}]$$

Call this \hat{V}_0 a complex amplitude or “phasor”

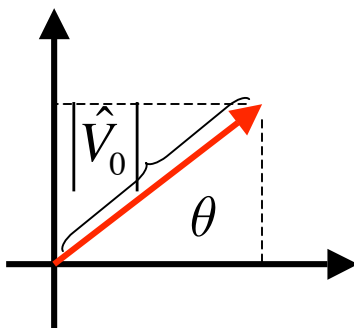

$$\hat{V}_0 = V_0 e^{j\theta}$$

$$|\hat{V}_0| = V_0$$

In this class, hat means a complex #

Magnitude of phasor gives peak amplitude of signal.

Angle give phase of signal.

$$V(t) = \text{Re}[\hat{V}_0 e^{j\omega t}]$$

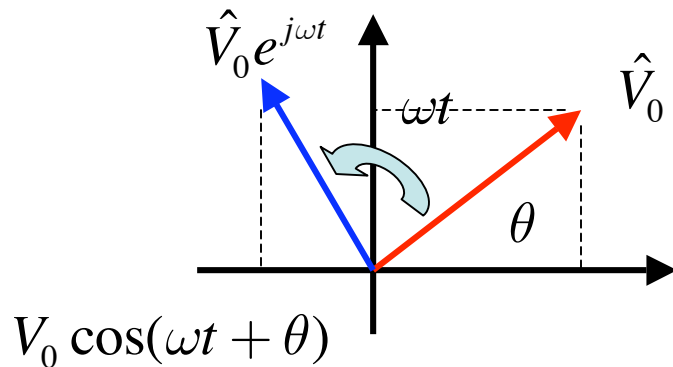

Multiplying \hat{V}_0 by $e^{j\omega t}$ rotates the angle of the product by ωt

Remember: $|Z_3| = |Z_1||Z_2|$
 $\theta_3 = \theta_1 + \theta_2$

How to use in circuits:

1. Every voltage and current is written in phasor form:

$$V_s(t) = \text{Re}[\hat{V}_0 e^{j\omega t}]$$

$$I(t) = \text{Re}[\hat{I} e^{j\omega t}]$$

$$V_L(t) = \text{Re}[\hat{V}_L e^{j\omega t}]$$

2. Write every circuit law in terms of phasors:

Example: Ohm's Law $V_R(t) = R I(t)$

$$V_R(t) = \text{Re}[\hat{V}_R e^{j\omega t}] = R \text{Re}[\hat{I} e^{j\omega t}] = \text{Re}[R\hat{I} e^{j\omega t}]$$

3. Drop the Real. Real parts are equal and let's say imaginary parts are equal too. Why not?

$$\hat{V}_R e^{j\omega t} = R\hat{I} e^{j\omega t}$$

4. Cancel $e^{j\omega t}$

$$\hat{V}_R = R\hat{I}$$

5. The result is the same Ohm's law we love, but with phasors!

What about Inductors?

$$V_L(t) = L \frac{d}{dt} I(t)$$

Substitute in phasors

$$V_L(t) = \text{Re}[\hat{V}_L e^{j\omega t}] = L \frac{d}{dt} \text{Re}[\hat{I} e^{j\omega t}] = \text{Re}\left[L \frac{d}{dt} \hat{I} e^{j\omega t}\right] = \text{Re}[j\omega L \hat{I} e^{j\omega t}]$$

Only t dependence



3. Drop the Real $\hat{V}_L e^{j\omega t} = j\omega L \hat{I} e^{j\omega t}$

4. Cancel $e^{j\omega t}$ $\hat{V}_L = j\omega L \hat{I} = jX_L \hat{I}$

5. The result is the same Ohm's law we love, but with resistance replaced by

$$jX_L$$

Back to our circuit

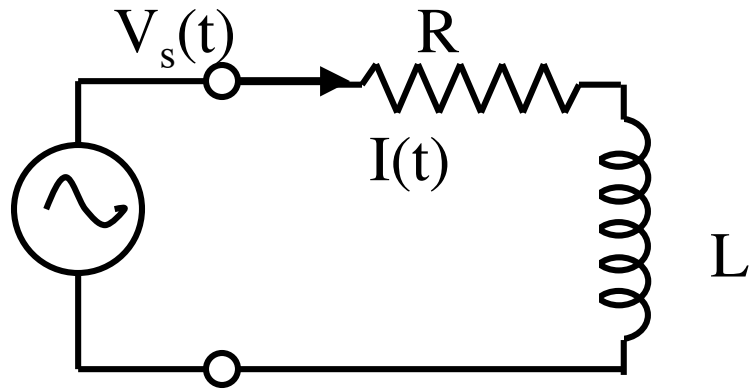

KVL: $\hat{V}_0 = \hat{V}_R + \hat{V}_L$

$\hat{V}_R = R\hat{I}$ $\hat{V}_L = jX_L\hat{I}$

Result: $\hat{I} = \frac{\hat{V}_0}{R + jX_L}$

Recall DC circuit result: $I = \frac{V_0}{R_1 + R_2}$

Bottom Line

Everything you learned about DC circuits can be applied to AC circuits provided you do the following:

1. Replace all voltages and currents by their phasor amplitudes. In practice this means putting a hat on each letter.
2. Treat inductors as resistors with “resistance” $j\omega L$
3. Treat capacitors as resistors with “resistance” $1/(j\omega C)$

RLC Circuit

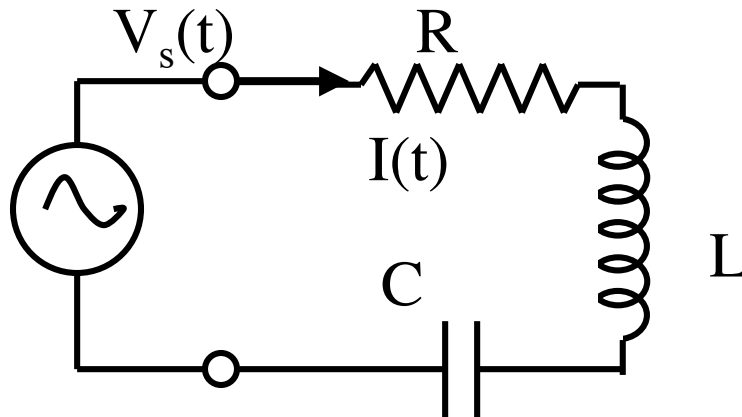

KVL

$$\hat{V}_0 = \hat{V}_R + \hat{V}_L + \hat{V}_C$$

$$\hat{V}_R = R\hat{I} \quad \hat{V}_L = j\omega L\hat{I} \quad \hat{V}_C = 1/(j\omega C)\hat{I}$$

Current phasor

$$\hat{I} = \frac{\hat{V}_0}{R + j[\omega L - 1/(\omega C)]} = \frac{\hat{V}_0}{Z}$$

Complex Impedance

$$Z = R + j[\omega L - 1/(\omega C)]$$

Magnitude of Impedance $|Z| = \sqrt{R^2 + [\omega L - 1/(\omega C)]^2}$

Phase of Impedance

$$\tan \phi = [\omega L - 1/(\omega C)] / R$$

Resonance: At what frequency is the amplitude of the current maximum?

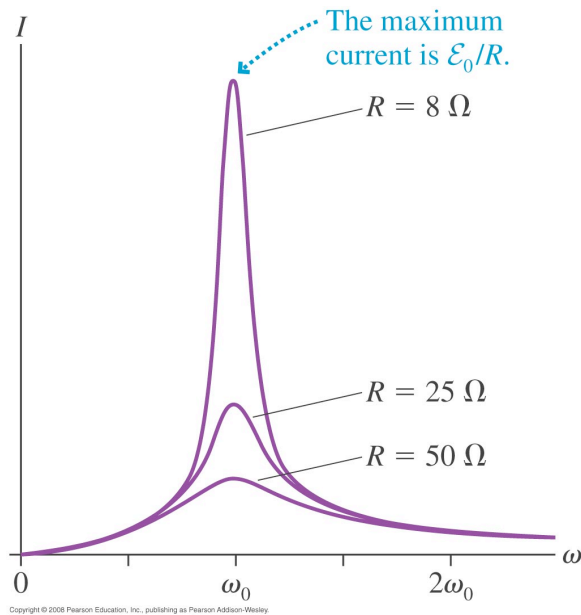

At resonance:

$$|\hat{I}| = \frac{|\hat{V}_0|}{R}$$

Complex Amplitude

$$\hat{I} = |\hat{I}| e^{j\theta} = \frac{\hat{V}_0}{R + j[\omega L - 1/(\omega C)]} = \frac{\hat{V}_0}{Z}$$

Current Amplitude

$$|\hat{I}| = \frac{|\hat{V}_0|}{|Z|} = \frac{|\hat{V}_0|}{\sqrt{R^2 + [\omega L - 1/(\omega C)]^2}}$$

Current is largest when this term is zero

$$\omega = \omega_0 = 1/\sqrt{LC}$$

Resonant frequency

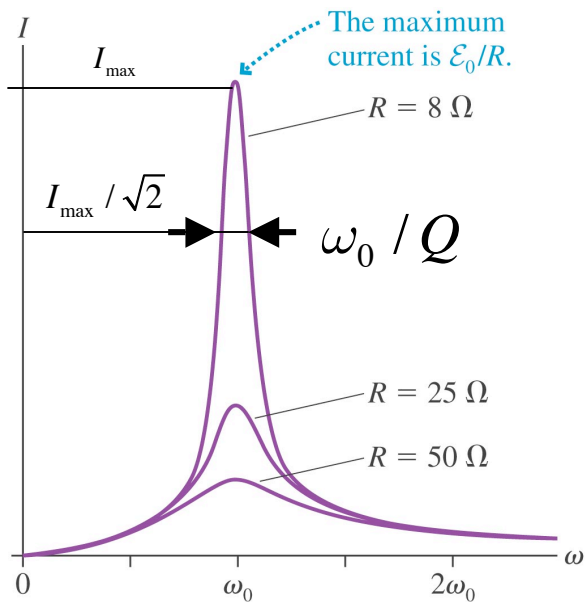

How narrow is the Resonance?

$$|\hat{I}| = \frac{|\hat{V}_0|}{|Z|} = \frac{|\hat{V}_0|}{\sqrt{R^2 + [\omega L - 1/(\omega C)]^2}}$$

Width of resonance determined by when these two are equal

$$Q = \sqrt{\frac{L}{C}} / R \quad \text{Quality Factor}$$

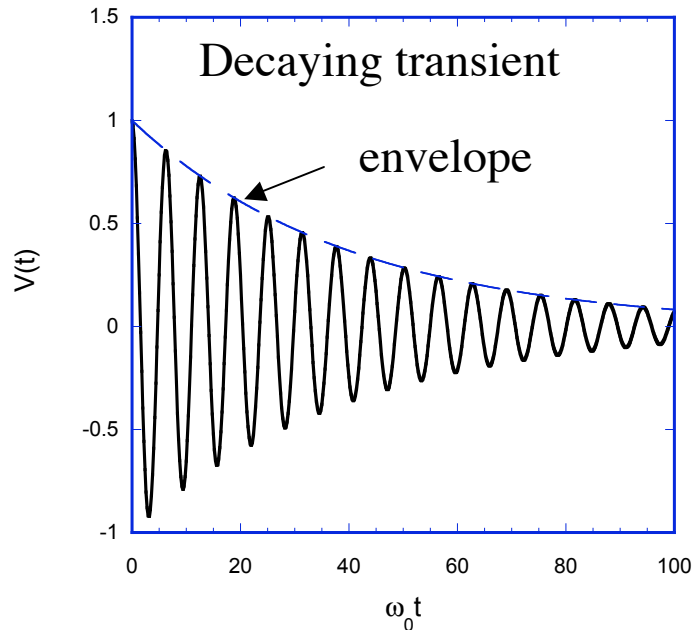

Quality factor determines rate of decay of transient

$$\text{envelope} = e^{-\omega_0 t / (2Q)}$$

$$\frac{\text{Power dissipated in } R}{\text{Energy stored in } L \text{ \& } C} = \frac{\omega_0}{Q}$$

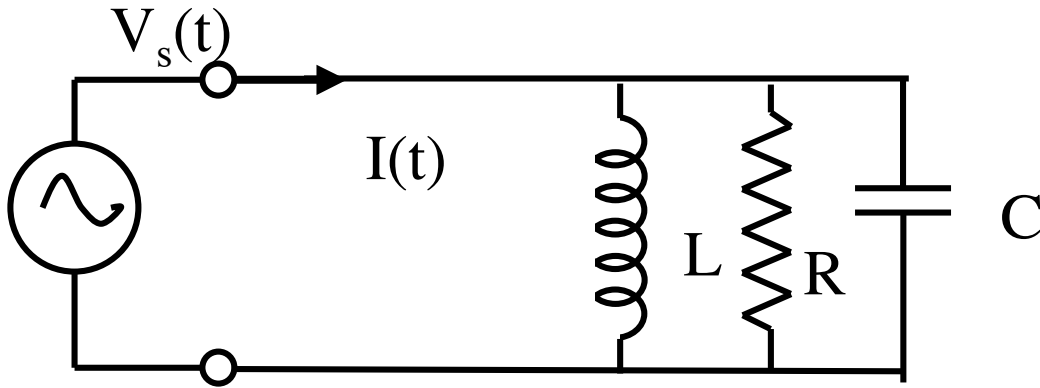

What is the impedance of the parallel combination of an R, L, and C?

- A $Z = R + j[\omega L - 1/(\omega C)]$
- B $Z = R - j[\omega L - 1/(\omega C)]$
- C $Z = 1/[R^{-1} + (j\omega L)^{-1} + j\omega C]$

Phasors for R-L circuit

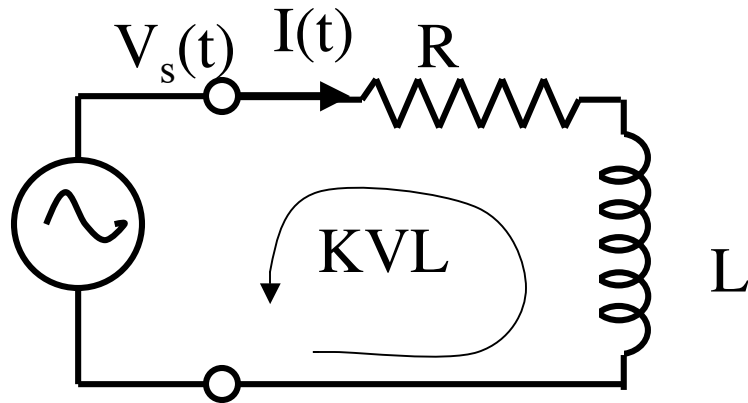

Write currents and voltages in phasor form

$$V_s(t) = \text{Re}[\hat{V}_0 e^{j\omega t}] \quad V_L(t) = \text{Re}[\hat{V}_L e^{j\omega t}]$$

$$I(t) = \text{Re}[\hat{I} e^{j\omega t}] \quad V_R(t) = \text{Re}[\hat{V}_R e^{j\omega t}]$$

Write circuit equations for phasor amplitudes

$$\text{KVL:} \quad 0 = \hat{V}_L + \hat{V}_R - \hat{V}_0$$

$$\hat{V}_L = j(\omega L)\hat{I} = jX_L\hat{I} \quad \hat{V}_R = R\hat{I}$$

Result:
$$\hat{I} = \frac{\hat{V}_0}{Z}$$

Impedance
$$Z = R + jX_L$$

Result: $\hat{I} = \frac{\hat{V}_0}{Z}$

Impedance $Z = R + jX_L$

Impedance has a magnitude and phase

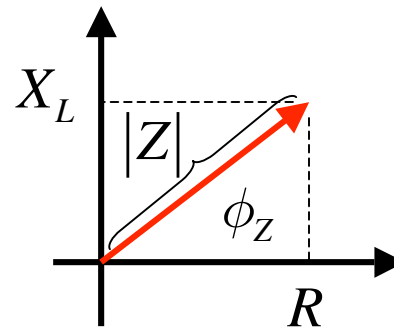

$$Z = |Z|e^{j\phi_Z}$$

$$|Z| = \sqrt{R^2 + X_L^2}$$

$$\tan \phi_Z = X_L / R$$

Resistor Voltage

$$\hat{V}_R = R\hat{I} = \hat{V}_0 \frac{R}{Z} = \hat{V}_0 \frac{R}{|Z|} e^{-j\phi_Z}$$

Inductor Voltage

$$\hat{V}_L = jX_L\hat{I} = \hat{V}_0 \frac{jX_L}{Z} = \hat{V}_0 \frac{X_L}{|Z|} e^{j(\frac{\pi}{2} - \phi_Z)}$$

Note: $j = e^{j\frac{\pi}{2}}$

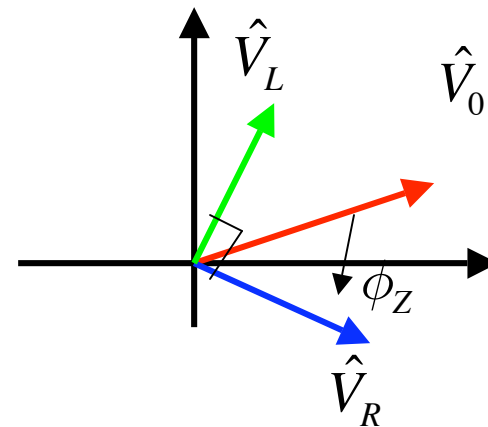

$$\hat{V}_0 = \hat{V}_L + \hat{V}_R$$

Power Dissipated in Resistor

Current

$$I(t) = I_R \cos[\omega t]$$

Instantaneous Power

$$p(t) = RI^2 = RI_R^2 \cos^2[\omega t]$$

Average over time is $1/2$

Average Power

$$P = \frac{1}{2} RI_R^2$$

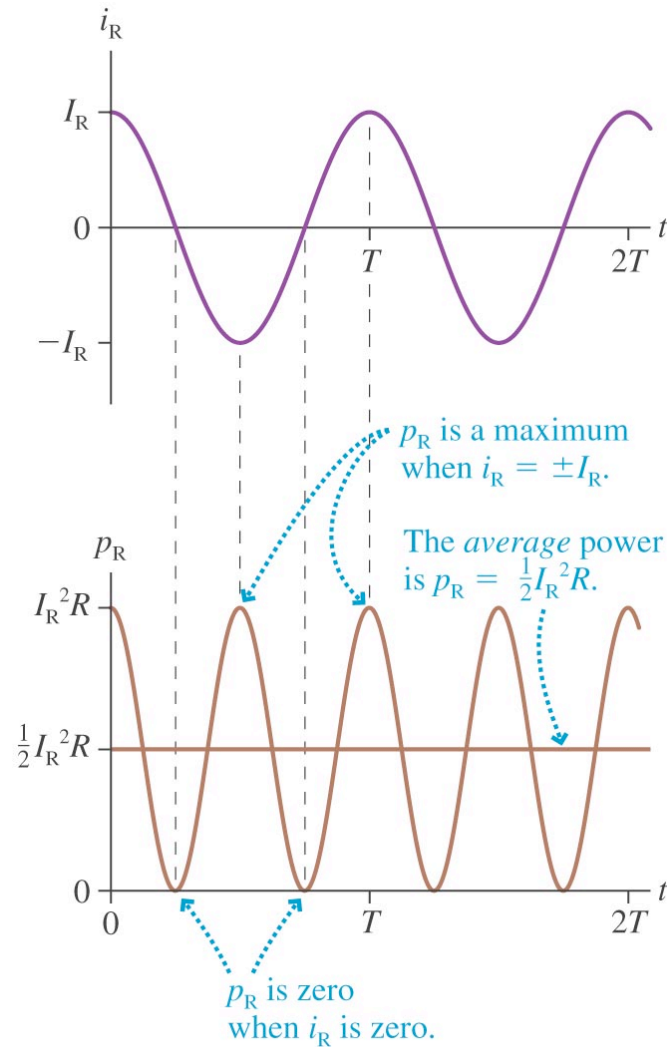

Root Mean Square (RMS) Voltage and Current

Current $I(t) = I_R \cos[\omega t]$ Average Power $P = \frac{1}{2} R I_R^2$

Peak current \nearrow

What would be the equivalent DC current as far as average power is concerned?

$$I_{RMS} = \frac{I_R}{\sqrt{2}}$$

Average Power $P = R I_{RMS}^2$ ← No pesky 2

What is the peak voltage for 110 V-AC- RMS?

A: 156 V

Power Delivered to a Capacitor

Voltage $V(t) = V_C \cos[\omega t]$

Current $I(t) = C dV(t) / dt$

$$I(t) = -\omega C V_C \sin[\omega t]$$

Instantaneous Power

$$p(t) = IV = -\omega C V_C^2 \cos[\omega t] \sin[\omega t]$$

$$p(t) = -\frac{\omega C V_C^2}{2} \sin[2\omega t]$$

Average Power $P = 0$

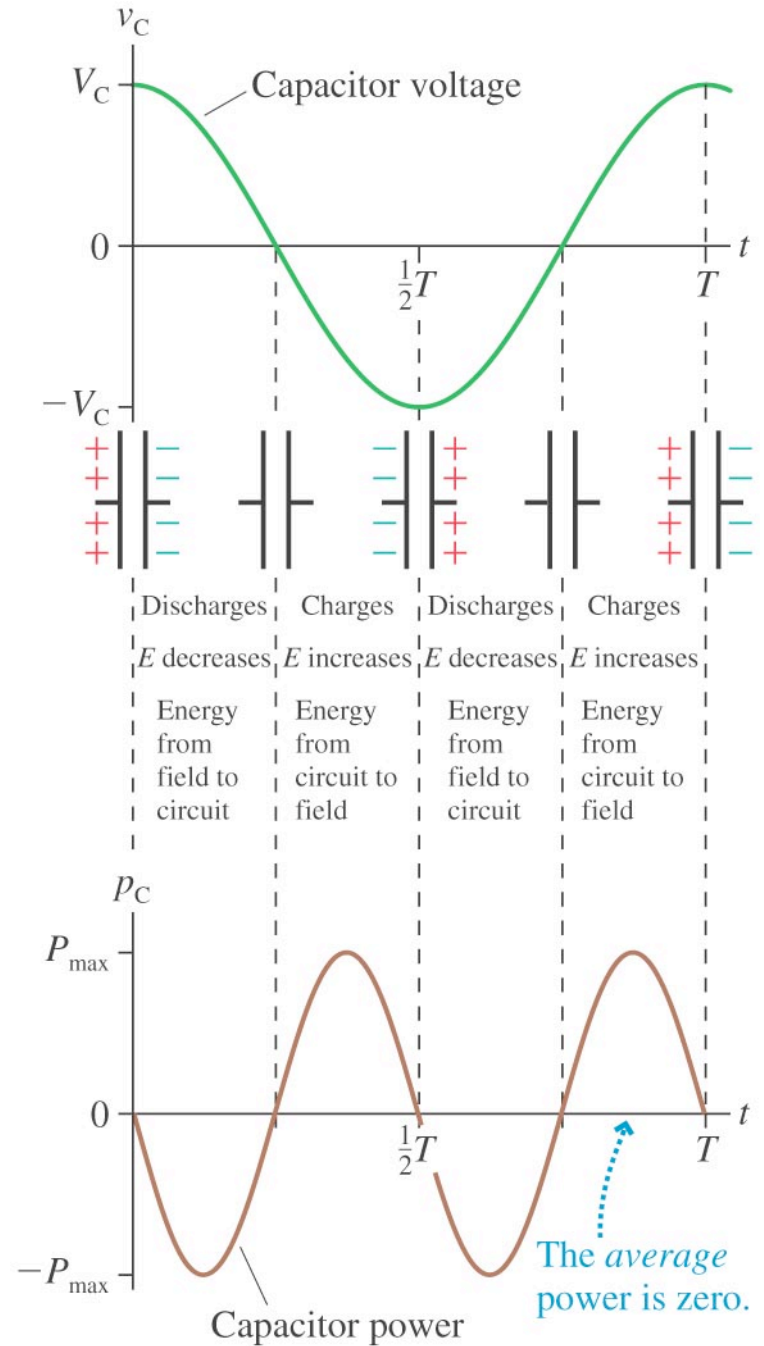



Rank in order, from largest to smallest, the cross-over frequencies $(\omega_c)_a$ to $(\omega_c)_d$ of these four circuits.

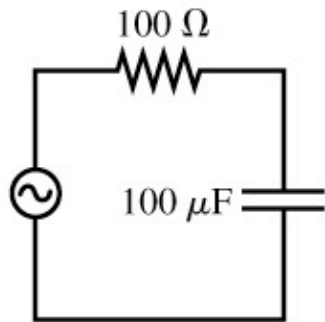

(a)

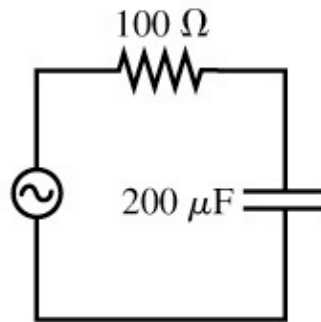

(b)

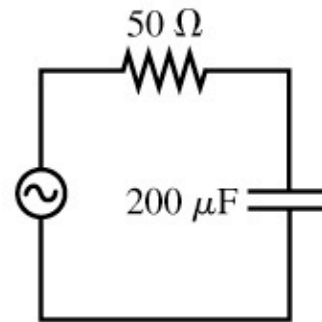

(c)

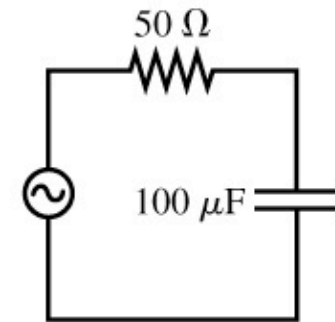

(d)

- A. $(\omega_c)_a > (\omega_c)_b = (\omega_c)_d > (\omega_c)_c$
B. $(\omega_c)_b > (\omega_c)_a = (\omega_c)_c > (\omega_c)_d$
C. $(\omega_c)_b = (\omega_c)_c > (\omega_c)_a = (\omega_c)_d$
D. $(\omega_c)_c > (\omega_c)_b = (\omega_c)_d > (\omega_c)_a$
E. $(\omega_c)_d > (\omega_c)_a = (\omega_c)_c > (\omega_c)_b$



A series *RLC* circuit has $V_C = 5.0$ V, $V_R = 7.0$ V, and $V_L = 9.0$ V. Is the frequency above, below or equal to the resonance frequency?

- A. Above the resonance frequency
- B. Below the resonance frequency
- C. Equal to the resonance frequency



The emf and the current in a series RLC circuit oscillate as shown. Which of the following would increase the rate at which energy is supplied to the circuit?

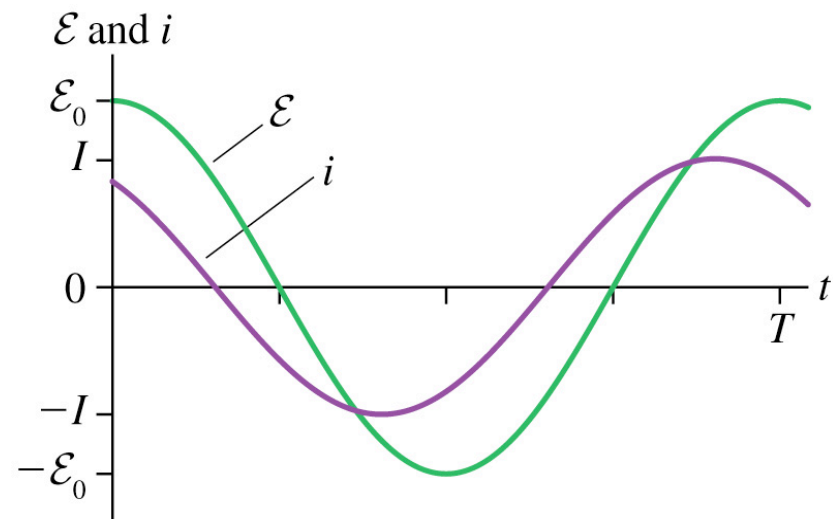

- A. Decrease ϵ_0
- B. Increase C
- C. Increase L
- D. Decrease L

Important Concepts

AC circuits are driven by an emf

$$\mathcal{E} = \mathcal{E}_0 \cos \omega t$$

that oscillates with angular frequency $\omega = 2\pi f$.

Phasors can be used to represent the oscillating emf, current, and voltage.

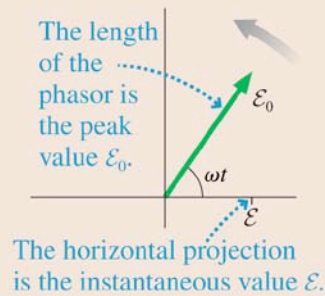

Basic circuit elements

Element	i and v	Resistance/ reactance	I and V	Power
Resistor	In phase	R is fixed	$V = IR$	$V_{\text{rms}} I_{\text{rms}}$
Capacitor	i leads v by 90°	$X_C = 1/\omega C$	$V = IX_C$	0
Inductor	i lags v by 90°	$X_L = \omega L$	$V = IX_L$	0

For many purposes, especially calculating power, the **root-mean-square** (rms) quantities

$$V_{\text{rms}} = V/\sqrt{2} \quad I_{\text{rms}} = I/\sqrt{2} \quad \mathcal{E}_{\text{rms}} = \mathcal{E}_0/\sqrt{2}$$

are equivalent to the corresponding DC quantities.

Copyright © 2008 Pearson Education, Inc., publishing as Pearson Addison-Wesley.

Key Skills

Phasor diagrams

- Start with a phasor (v or i) common to two or more circuit elements.
- The sum of instantaneous quantities is vector addition.
- Use the Pythagorean theorem to relate peak quantities.

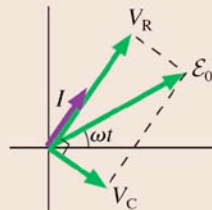

For an RC circuit, shown here,

$$v_R + v_C = \mathcal{E}$$

$$V_R^2 + V_C^2 = \mathcal{E}_0^2$$

Kirchhoff's laws

Loop law The sum of the potential differences around a loop is zero.

Junction law The sum of currents entering a junction equals the sum leaving the junction.

Instantaneous and peak quantities

Instantaneous quantities v and i generally obey different relationships than peak quantities V and I .

Copyright © 2008 Pearson Education, Inc., publishing as Pearson Addison-Wesley.